



**SERVICE-LEARNING FOR  
PRIMARY EDUCATION**

**Toolkit and teacher guide**

**Alžbeta Brozmanová Gregorová, Barbara Švidraň Basarábová et al.**

2024

# SLIPS

## Service Learning In Primary Schools

Main authors: Alžbeta Brozmanová Gregorová, Barbara Švidraň Basarábová  
Coauthors: Daniela Ivanová, Lucia Rossová  
Reviewers: Filipa Cabral, Mirian Hervas Torres, Jasmin Jasarevic. Saulius Mickevicius, Martina Potlimbrzović, Tenna Sørensen Jochumsen,

Project partners: Centre for European Volunteering (CEV)  
Out of the Box Europe (OTB)  
Croatian Volunteer Development Centre (CVDC)  
Platform of Volunteer Centres and Organizations (PDCO)  
Vytautas Magnus University (VMU)  
University of Granada (UGR)  
PRONI Center for Youth Development (PRONI)

Publisher: Platform of Volunteer Centres and Organizations, Slovakia  
Year of publishing: 2024  
Scope: 6,5 authors sheets  
ISBN: 978-80-69023-02-4  
EAN: 9788069023024  
DOI: <https://doi.org/10.5281/zenodo.14555918>

Call: ERASMUS-2023-PCOOP-ENGO  
Project Number: 101134702  
Deliverable: D 3.1.



*Funded by the European Union. Views and opinions expressed are however those of the author(s) only and do not necessarily reflect those of the European Union or Léargas. Neither the European Union nor the granting authority can be held responsible for them.*



Published under the Creative Common licence Creative Commons Attribution-NonCommercial-No-Derivates 4.0 International Licence CC BY-NC-ND

## Content

Content .....	2
About the SLIPS toolkit .....	4
First part:.....	5
Introduction to the service-learning in the primary education context .....	5
1. Service-learning definition and critical components .....	6
2. Service-learning is not volunteering.....	8
3. Types of service in service-learning.....	8
4. Why service-learning in primary education .....	10
5. Service-learning as a process .....	13
6. How to design a meaningful service-learning project with primary school kids.....	16
Second part: .....	17
Service-learning step-by-step guide for teachers .....	17
1. Preparation or before you start working with children .....	20
1.1. Communicating about service-learning with school leadership .....	20
1.2. Communication with other teachers about service-learning .....	22
1.3. Communication about service-learning with families.....	22
1.4. How to prepare a plan for working with children.....	23
1.5. How to set learning objectives in service-learning.....	24
1.6. What approach to take to mapping needs in the community or where to map needs	32
1.7. How much time to allocate for service-learning implementation? .....	34
2. List of activities in each phase of work with pupils .....	38
3. Introductory activities - laying the groundwork for service-learning .....	40
3.1.1. How to explain what service-learning is or how to inspire and motivate pupils	40
3.1.2. How to set personal development goals with pupils .....	48
3.1.3. Rules and teamwork .....	49
4. Mapping the community .....	54
4.1. Before you take the kids into the field .....	54
4.2. Community survey, problem selection and analysis.....	61
5. Project planning.....	72
5.1. Explanation of the project cycle .....	72
5.2. Objectives of the service in the service-learning project.....	74



5.3.	How to combine learning objectives and service objectives .....	81
5.4.	How do we involve the community? .....	86
5.5.	Planning activities to achieve objectives .....	89
6.	Action .....	99
6.1.	Tips for activities with children in the action phase .....	100
7.	Reflection during and at the end of the project.....	108
8.	Monitoring and documentation during and at the end of project implementation....	122
9.	Promotion and communication as part of a service-learning project .....	126
10.	Evaluation.....	127
10.1.	Evaluation of the achievement of learning objectives.....	127
10.2.	Evaluation of a service-learning project .....	135
11.	Celebration .....	141
	References:.....	145
	Third part: .....	147
	Workbook for children – selected activities.....	147



## About the SLIPS toolkit

This toolkit was created as a result of the Service Learning in Primary Schools (SLIPS) project. The project partners created it based on their knowledge and experiences with service-learning implementation in schools and universities, the research and need assessment conducted in the SLIPS project, and the methodology and experiences implementing the [SLUSIK project](#) with secondary school children.

Toolkit is dedicated to teachers who want to implement service-learning projects with their primary school children. We aim to introduce only some of the service-learning methodologies. You can use several other sources to learn more about the service-learning approach you can find in your or another country. Please check [the Report from the mapping in the SLIPS project](#).

Therefore, we decided to focus on more practical tools for primary school settings. We adopted effective tools in secondary and higher education for primary education in European settings. The first draft of the toolkit was tested with 14 teachers from Slovakia, Belgium, Bosnia and Herzegovina, Croatia, Portugal, Spain and Lithuania. They provided feedback, which we used to develop the final version that you can see.

The toolkit can be printed or used electronically. We suggest you also consider environmental considerations and print as many copies as you need. **The first part** offers a basic explanation of the service-learning methodology and its steps. **The second part** is a step-by-step guide for teachers. You can also download this guide as a separate document here (a link will be provided). **The third part** of the workbook is designed for children. Also, you can find it in a separate document. For the workbook for children, you can use the sheets for your chosen activities to create your kid's service-learning journey. Copy the first page and then the other pages as the project goes. Children can also add to the workbook other documentation from the project: notes, pictures, drawings, and reflections. It can be their unique book documenting their story and accomplishments.

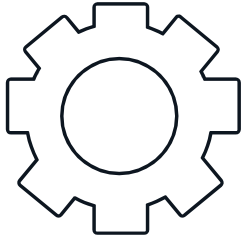

**First part:  
Introduction to the  
service-learning in the  
primary education  
context**

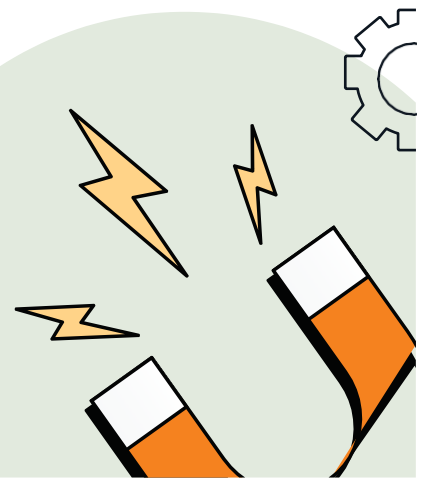

## 1. Service-learning definition and critical components

Service-learning is defined as an educational approach capable of promoting student active participation and the integration of curricular elements outside the classroom. You will encounter many definitions for this term in the vast literature, publications and projects about service-learning. The authors also delve into many steps for implementing this strategy and present a wide range of activities that can be considered service-learning projects. Different approaches have been developed for various levels of education, considering the unique characteristics of students involved or leading the service-learning project, their capabilities and the educational objectives. It is important to note that this chapter only aims to summarise some of these approaches, as they are already well-documented and summarised in other sources. This chapter aims to introduce the basic features of service-learning in the context of primary education and select a topic to understand the concept better as an essential precondition for successful service-learning implementation with kids.

Service-learning combines two well-known educational methods in active pedagogies: experiential learning and community service action (Lucas-Mangas & Martínez-Odría, 2012). It involves implementing actions that benefit society and the student community, resulting in reciprocal benefits between those who provide the service and those who receive it. This convergence of actions allows the student to become an active person capable of solving different social problems in their environment. Service-learning, therefore, involves an educational proposal that combines learning processes and community service in a single well-articulated project in which participants learn to work on the real needs of the environment to improve it (Puig-Rovira et al., 2011).

Service-learning is not just a teaching and learning approach but a practical and real-world application of knowledge. It combines planned learning and community service, focusing on an activity that benefits the community and its educational benefits for the student. Service-learning empowers students to achieve specific learning outcomes through active community engagement and real-life solutions in practice. The process of learning is supported by reflection as a necessary part of experiential learning. These practical aspects of service-learning are a vital feature that sets it apart from other pedagogical approaches.

Service-learning differs from traditional forms of learning because it brings course content to life by providing students with opportunities to apply their knowledge in real-world settings to benefit other people, communities, or societies. Service-learning also endeavours to instil a sense of civic engagement and responsibility. It is not about adding engagement to learning but rather about integrating engagement within the learning process.

Following a review of research on service-learning to demonstrate its pedagogical possibilities, authors (for example, Martínez-Odría, 2007; Lucas et al., 2024 and others) identify specific

components that a service-learning project should include and that differentiate it from other community-based educational experiences and volunteer services (see Table 1):

Table 1: Key components of a service-learning project	
<b>Attention to a real need</b>	Service-learning is a pre-planned and organised student experience gained through a service that responds to the authentic needs of the community through a horizontal model of solidarity. Detecting a real need is decisive in determining the project's focus and the success of its results.
<b>Student protagonism</b>	Service-learning is based on active student involvement in all stages, from planning to assessment. Students should feel ownership of the project and act as leaders of activities, not just their implementers. Service-learning works with real student experiences and involves metacognitive learning, where the student is aware of how they learned, what they learned, what helped them learn, how they can use it in practice, and what they need to learn.
<b>Connecting curricular objectives</b>	Service-learning is intentionally integrated into the school curriculum. Its methodology can be incorporated into the curriculum of various subjects, either within one specific subject or through a combination of several subjects/teachers to solve interdisciplinary projects. The project's design, execution, and evaluation follow the objectives of each curricular area involved in its development.
<b>Reflection</b>	Service-learning allows students to reflect on the experience. Reflection guides the learner, facilitating an in-depth understanding of the connections between experiences and service-learning concepts.
<b>Civic focus</b>	Service-learning aims to develop civic responsibility in students, develop competencies for living in a democratic world, and change their civic characteristics. It enables students to be introduced to the role of civil society and how it functions, such as volunteering and funding mechanisms, as well as the importance of engagement with the local community.

Each of these criteria should be seen more as a continuum. You may not be able to reach the highest level in all requirements right from the start, and in some cases, it may not even be possible. However, it is essential to consider these three critical service-learning characteristics when planning and implementing projects.

## 2. Service-learning is not volunteering

Service-learning and volunteering are very similar concepts, comprising some unpaid engagement and learning, but they also have differences.

Table 2: Difference between Service-Learning and Volunteering		
Dimension	Service-learning	Volunteering
What is it	Teaching and learning strategy	Action or activity performed by individuals for other people, the community and the common good
Main aim	Develop knowledge, skills and competencies of students and, at the same time, solve real issues and challenges in the community or organisation.	Provide service or offer help, solve real issues and challenges in the community or organisation.
Learning component	Learning is planned and intentionally integrated into the curriculum	Learning occurs, but it is usually not pre-planned or reflected.
Service component	Respond to the authentic needs of the community or organisation.	Respond to the authentic needs of the community or organisation.
Financial award	Unpaid activity	Unpaid activity
Free will	Can be mandatory or optional	Optional, free choice

## 3. Types of service in service-learning

Several service-learning models are in practice. Service-learning can be incorporated into the curriculum of various subjects. It can be implemented within one subject or combined with several subjects to solve interdisciplinary projects. It can be part of a compulsory or elective educational process and organised as a group or individual activity.

Service-learning students can be involved in a wide range of community organisations that provide a spectrum of services, including, but not limited to, social services, sports and recreation, arts and culture, education and research and environmental causes. What students will do as a service component will depend on the educational outcomes (learning part), service-learning model and the community partner's needs, community or beneficiaries.

**Table 3: Four types of service in service-learning**

<b>Direct Service</b>	<p>Direct service projects involve students in activities where they directly interact with the beneficiaries.</p> <p><u>Examples in primary education can include:</u></p> <p><b>Reading Buddies Program:</b> Older primary students read to younger children in a local preschool.</p> <p><b>Community Clean-Up:</b> Students participate in cleaning up local parks, playgrounds or community centres. They interact with community members to understand the importance of a clean environment and take immediate action to improve their surroundings.</p> <p><b>Senior Companion Visits:</b> Students visit local senior centres to spend time with elderly residents. Activities can include reading, playing games or simply chatting, fostering intergenerational connections and providing companionship to the elderly.</p>
<b>Indirect Service</b>	<p>Indirect service projects involve students in activities that benefit the community without direct interaction with the beneficiaries.</p> <p><u>Examples include:</u></p> <p><b>Recycling Program:</b> Students organise a school-wide recycling program, collecting recyclable materials and ensuring they are correctly sorted and sent to recycling facilities.</p> <p><b>Book Drive:</b> Students collect gently used books to donate to schools, libraries, or shelters in need.</p> <p><b>Garden Projects:</b> Students create and maintain a community garden, providing fresh produce to local food banks or shelters or they build and maintain green spaces in the school.</p> <p><b>Restoring spaces:</b> Children restore some parts of the school by painting murals.</p>
<b>Advocacy</b>	<p>Advocacy projects involve students raising awareness and promoting action on issues of public interest.</p> <p><u>Examples include:</u></p> <p><b>Anti-Bullying Campaign:</b> Students create posters and presentations to raise awareness about the effects of bullying and promote a positive school environment. They might present their work to classmates, families, and community members.</p> <p><b>Environmental Awareness:</b> Students campaign to educate their school and community about environmental issues like pollution, conservation, and climate change.</p> <p><b>Health Awareness:</b> Students promote healthy lifestyles by organising “Healthy Eating Week,” creating informational materials about nutrition</p>

	and exercise, and encouraging their peers and community to adopt healthier habits.
<b>Research-Based Service-Learning</b>	<p>Research-based service-learning projects involve students in research activities to address defined community needs.</p> <p><u>Examples include:</u></p> <p><b>Community Needs Assessment:</b> Students conduct surveys and interviews within their community to identify critical issues and needs. They analyse the data and present their findings to local government or community organisations, helping to inform future initiatives.</p> <p><b>Wildlife Conservation Research:</b> Students research local wildlife habitats and the impact of human activities on these environments. They might create a report or presentation with recommendations for conservation efforts and share it with local environmental groups or authorities.</p> <p><b>Historical Preservation Project:</b> Students research the history of their local community, identifying significant historical sites and stories. They create a digital archive or a booklet to preserve this history and present it to the local historical society or library.</p>

The different types of service learning can also be combined in some cases.

#### 4. Why service-learning in primary education

Primary education provides learning and educational activities typically designed to provide students with fundamental skills in reading, writing and mathematics (i.e. literacy and numeracy) and establish a solid foundation for learning and understanding core areas of knowledge, skills and abilities and personal development, preparing for lower secondary education. It focuses on learning at a basic level of complexity with little, if any, specialisation (ISCED level 1) (ISCED, 2011).

Despite the many cultural and political differences among nations, the objectives and curriculum of primary education are similar. Nearly all countries are officially committed to mass education, which is viewed as eventually including a complete primary education. An increasing agreement may be found among nations to the effect that preparation for citizenship is one of the significant objectives of primary education. In terms of curriculum, this objective suggests an emphasis on reading and writing skills, arithmetic skills and basic social studies and science (Britannica, 2024).

The objectives of primary education expect pupils to be activated in their learning and the acquisition of values. Primary education is primarily aimed at developing functional literacy and acquiring the tools to learn about the world around them and the phenomena in it. Primary education should also create the conditions for developing social and civic competencies. The psychological characteristics of the child of younger school age confirm this approach. Thinking

in this developmental period is conceptually abstract, but the child can think about objects and phenomena that he can perceive directly. The basis of cognitive processes is the child's experience, which is then reflected upon by the teacher or other guide in the learning process. At the same time, however, the author Oravcová (2015) points out that this period is also characterised by the fact that it enables the perception of cause and effect relationships, links various thought processes, and logical thinking enables not only the classification and sorting of concepts and relationships but also the ordering of objects according to multiple criteria. Children at this age can only consider some factors related to the reality under investigation.

The characteristics of the development of cognitive processes also influence the recommended methods and forms of teaching. For the comprehensive development of a child of younger school age, i.e. in the period of the first stage of primary school, it is necessary to promote such educational situations in which the pupil satisfies his curiosity, interest and need for manipulation of objects and phenomena, learns through experimentation, exploration, research, verification of his theories. In the case of social relationships, it is necessary to create situations and stimuli that not only encourage but also strengthen the formation and maintenance of friendship bonds. It is essential to create an environment in which the needs and wishes of other people, including peers, are respected. This includes empathy, mutual understanding and a willingness to listen and adapt one's behaviour in the interests of harmonious coexistence. In this way, trust is built and healthy interpersonal relationships are fostered, which are the basis for the functioning of society. Also crucial for children of this age is the need for positive evaluation from other people. According to research in the field of learning, it is essential for the success of pupils of younger school age to develop cognitive functions. The curricula implemented in primary education encourage teachers to develop learners' knowledge, skills and abilities through activating teaching methods. Active involvement of pupils in the learning process, e.g. through exploratory activities or experimentation, by solving practical tasks and real-life problems, could be a way to promote the development of desirable knowledge as well as the necessary skills and competencies of pupils (Hall, 2020).

Research indicates that integrating service-learning into primary school curricula can be particularly beneficial. It allows young students to develop empathy, expand their understanding of social issues, and cultivate a lifelong commitment to community involvement. In Europe, where service-learning is still relatively nascent compared to the United States, educators are exploring incorporating this pedagogical approach into primary school settings. Studies have shown that service-learning in primary schools can lead to improved academic performance, enhanced leadership skills and a greater sense of social responsibility (Lake & Jones, 2008; Paredes & Martínez, 2016; Richards et al., 2013). For example, a pilot program in a large, urban Midwestern city found that fifth- and seventh-grade students participating in a service-learning curriculum demonstrated significantly higher scores on leadership measures than their peers in the control group (Richards et al., 2013). Similarly, an article addressing service-learning in elementary classrooms emphasises the importance of integrating a year-long approach to community service, allowing children to make meaningful connections to their



local communities while developing lifelong habits of participation and civic engagement (Fox, 2010).

### Service-learning should be an appropriate method for teaching and learning in primary education for several compelling reasons:

- Introducing service-learning at an early age **helps to lay the foundation for lifelong learning and responsible citizenship**. Primary school students are at a formative stage, where they can develop core values and skills to influence their future behaviours and attitudes.
- Service-learning integrates school curriculum with meaningful community service, **making learning more relevant and engaging**. It helps them understand subject content by allowing them to apply what they have learned in real-world contexts.
- Young children benefit immensely from the social interactions and emotional growth facilitated by service-learning. **It helps them develop critical social skills** such as teamwork, communication, and empathy.
- Service-learning **challenges students to think critically and solve real-life problems**. This nurtures their ability to analyse situations, consider different perspectives, and devise innovative solutions.
- Service-learning **makes education more motivating for young students**. They see the direct impact of their efforts, which boosts their enthusiasm for learning and encourages active participation in their education.
- Service-learning projects often involve collaboration with peers, teachers, and community members. This **helps students connect to their community and fosters a sense of belonging**.
- Through service-learning, primary school students are exposed to diverse groups and community issues, promoting inclusivity and understanding. This early exposure **helps to combat stereotypes and prejudices**, fostering a more inclusive and accepting mindset as they grow.
- Service-learning instils values of civic responsibility and social justice in young students. **They learn about societal issues and the importance of taking action to address them**.
- Service-learning aligns with the **goals of holistic education**, which seeks to develop the whole child. It addresses cognitive, social, emotional, and ethical development.
- The skills and values gained through service-learning in primary education **prepare students for future academic, personal, and professional challenges**. They become more adaptable, resilient, and capable of navigating complex situations, essential in an ever-changing world.

In summary, developing service-learning in primary education equips young students with essential skills, values and attitudes that benefit their academic growth, personal development and civic engagement. It fosters a comprehensive educational experience that prepares them to be active, empathetic, and responsible citizens.

We offer you other tips for service-learning projects with links to areas of the primary education curriculum. Of course, children also develop other critical knowledge, skills, and

competencies mentioned above, and they also develop relationships in the classroom and with the broader environment.

Table 4: Service-learning project ideas in connection with selected areas of primary school curriculum	
<b>Reading Curriculum</b>	Literacy programs for younger kids Reading clubs with seniors Little free library in the community
<b>Environment and Science Curriculum</b>	Community Garden Tree planting with tree care Campaign to promote recycling, reduce litter, or increase biodiversity in school or neighbourhood Research a unique environmental challenge in their area and design a specific project to improve it. Improvement of a local park Pollinator garden to help bees
<b>Art Curriculum</b>	Mural in a public space or a community art exhibition with community members Making crochet hearts in the community

## 5. Service-learning as a process

Different sources recognise different stages in service-learning implementation. The recognised steps are mostly preparation, planning, need assessment, action, evaluation, and celebration. Reflection is sometimes recognised as a separate step. However, because it should be seen more as a continuous process, we recommend seeing reflection as a constant process with promotion and documentation. Partners created the PLACE model in the SLUSIK project, recognising the stages: Prepare, Link, Action, Celebrate, and Effect.

The next part summarises each step based on the different sources. The guide provides more information and concrete tools for each step in the next section.

### *Preparation.*

This stage is all about preparing and designing the SL experience. It helps you understand if you and your school are ready to implement service learning and, if not, what you need to do to be prepared.

### *Need assessment and planning.*

The starting point in service-learning is to identify a need or problem of the local community which the project will address. In other words, in this step, it is crucial to find out what the local community needs are and how the youngsters implementing the project can respond to them. At this stage, the objective of learning and service should also be defined. Once the topic and scope of the project are identified, it is time to move on to the planning of the activity.

Depending on the kind of project the kids will implement, they must plan slightly differently. However, the planning will always involve defining tasks and their distribution, communication in the group, preparation of the project schedule, and budget planning. The kids may also need extra education in specific issues - gain particular knowledge or develop certain skills.

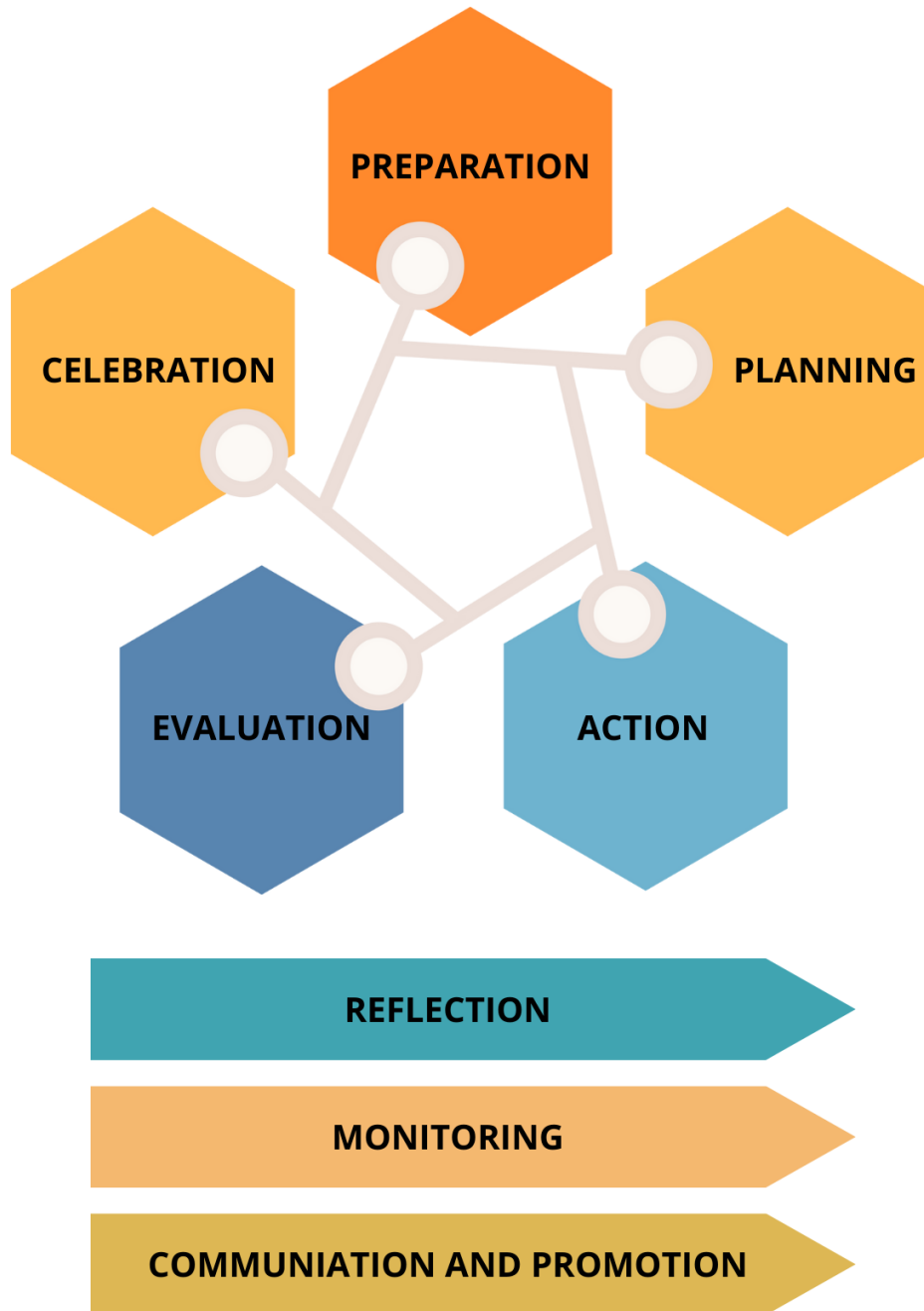



### *Action.*

This step is the actual activity or project kids have prepared with the community. Sometimes, the preparation itself takes less time than the activity itself. It depends on the types of activities. Longer commitment is advisable; service-learning projects should be sustainable in the long term. When the activity is recurrent, there will also be time to reflect on it between individual events, discuss the learning process and emerging difficulties, look for solutions and introduce any modifications.

### *Evaluation.*

Once the kids have completed the activity, it is necessary to discuss it, summarise it, conclude the future, and analyse the service and the learning process in the context of the whole group and each participant. This is an essential stage of reflection on the project because you can look at it from a broader perspective: Did the preparation process match the implementation of the activities? Is the problem solved? Or was the support provided only accidental? Would it make sense to repeat the activity in the future? Does it require any modification or a complete change?

### *Celebration.*

This stage is also a meaningful part of the project, which, unfortunately, sometimes gets forgotten. Make sure you plan a meeting or trip to conclude the whole process and allow you to show and appreciate your participants' achievements. Let kids take pride in what they have done!

### *Reflection.*

Reflection is considered a key "ingredient" that transforms experience from service activity into learning; it has a vital role in awareness-building and transforms service-learning into critical pedagogy, potentially inspiring personal transformation and driving social change (Jacoby, 2015).

### *Communication and promotion*

Communication is a continuous process among the project participants, the institution, community partners, and the community. An optimal service-learning project involves creating effective communication channels that foster a sense of connection and engagement between the participants and the community.

### *Monitoring*

Maintaining ongoing project monitoring is an often-overlooked aspect of a quality service-learning experience. Monitoring the learning and actions taken throughout the project, as opposed to after the project is completed, provides valuable information for the reflection processes, evaluation, and promotion of the project.

## 6. How to design a meaningful service-learning project with primary school kids

Unfortunately, many school service-learning projects are not meaningful (for the learner or the intended community being served). Designing a service-learning project that makes a lasting impact takes more pre-planning and investment, but when done right, it is one of the most transformative learning experiences your child can have.

Here are some general guidelines that you can use to design service-learning projects with kids in primary schools. [Prisma](#), [EDUVOL](#) and the [SLUSIK](#) project and interviews with teachers during the SLIPS project research stage inspire them:

- **Enlist school leadership, colleagues, and families to implement the project.** The essential prerequisites for the successful development of service-learning at school is an atmosphere that motivates everyone to take an interest in what is happening in our surroundings, take an interest in helping others, and allow children's activities to be supported and appreciated. Try to build it together with people who are connected with the school.
- **Recognize that service can take many forms.** You might initially think direct service is the only way to conduct service learning. However, indirect service or advocacy can be equally meaningful, especially if your child learns about an issue or cause.
- **Designing a meaningful service-learning project begins with understanding your community's needs.** Need assessment is a vital first step and can help build academic skills in reading, writing, and organising sources.
- **Connect the project to your child's interests.** If your children love animals, a project could involve supporting a local animal shelter. If they are passionate about the environment, they could plant trees or initiate a recycling program. When kids can connect learning to their interests, they are much more motivated to do their best, meaning that their ultimate service project will have much more impact.
- **Ensure the project is age-appropriate.** Primary school students might engage in more straightforward projects than older students.
- **Effective service is collaborative.** Leverage partnerships and look for opportunities to add to existing work. Contact local nonprofits and community partners. Identify where help is needed and how your children can contribute.
- **The most impactful service is year-round.** Rather than dropping in once per year to volunteer, consider building a relationship with a favourite organisation as a family. This way, your children will build bonds with staff and the community, gradually build expertise in the area of need the organisation impacts, and benefit from seeing the long-term payoff of their work.
- **Be a role model for children.** In this way, you are not only offering children a role model and modelling their behaviour but also creating shared memories and teaching children values that will help them in the future.
- **Be inclusive.** When engaging in service-learning, consider the different needs of children, such as time demand, attendance, accessibility, or need for assistance, to ensure that everybody in your class can participate.

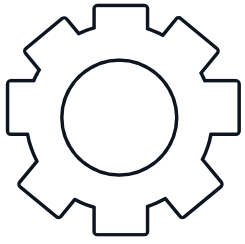

# Second part: Service-learning step-by- step guide for teachers



Service learning is an experiential learning strategy. With an experience, you cannot thoroughly plan what it will look like, the outcomes, or what the children will learn in the experience. Therefore, in service learning, it is essential to understand the underlying frameworks and be aware of the standards to guide you in each year of implementation. Again, of course, there are myriad different checklists. We offer one based on evaluating service-learning projects in the service-learning award for schools in Central and Eastern Europe [Regional service-learning award](#). It can also serve as a checklist during or at the end of your project. You can print it out and hang it somewhere in your classroom. These three points also correspond to the key service-learning characteristics in this toolkit's first part.

### MOTIVATION AND PROTAGONIST ROLE OF STUDENTS



In service-learning, students are not mere recipients but the driving force behind their actions, with others benefiting from their efforts. This approach, which views participation as a right, is a cornerstone of democratic societies. It involves students in concrete actions aimed at transforming or improving something. Often, students are involved in service-learning experiences planned by the institution, its head authorities, or teachers. The service-learning pedagogical proposal aims to empower them to jointly introduce the problem, design, plan, implement, reflect on the actions, and evaluate the project.

### SERVICE-LEARNING EXPERIENCE WORKING WITH THE COMMUNITY



The service-learning practice is not a solitary endeavor, but a collaborative effort in response to a real community problem. It aims to diminish, temper, or contribute to solving the problem with other actors. In service-learning experiences, service is not seen as charity, but as a way to recognize the needs, unfair situations, or rights that should be protected. It encourages critical reflection and aims to lead to social transformation, fostering a sense of connection and community among all involved.

## LINKAGE TO CURRICULUM



Service-learning projects are pedagogically intentional, improving the quality of learning and offering an active response to a community's natural and pressing needs. It is essential for these proposals that curricular content is put into practice in the service-learning actions and that it allows students to develop curricular skills and content as well. Linking a practical experience in the community to formal learning will enable students to apply knowledge and skills to real contexts and develop effective and active citizenship for the community's benefit. Integrating these practical experiences with curricular content in specific areas or subjects also promotes thoughtful reflection on the student's activities and learning process.

Combining curricular content enables students to progressively build a more complex vision of the world, allowing them to tackle everyday problems better. Interdisciplinarity among curricular areas or fields allows for a multidimensional way of working, as it addresses the issues from different perspectives.

In this section, we also offer practical tips on the individual steps and ongoing processes in service learning. These are also nicely shown on this map, created as part of the [Eduvol project](#).

## Steps of service-learning



Source: Eduvol Facilitation Box for service-learning

## 1. Preparation or before you start working with children

In some manuals, this step is also called the motivation step. If you are new to service learning, preparing yourself and your colleagues, school leaders, and families is essential to implement this strategy. All of these groups can influence the implementation of your intentions positively or negatively. So, if you want to achieve and accept the change, it is ideal to prepare people for it and involve them in it so they are part of it. At the same time, you must consider your plan for implementing service-learning in this step. What form of service-learning will you choose? Plan your learning objectives and think through your timeline.

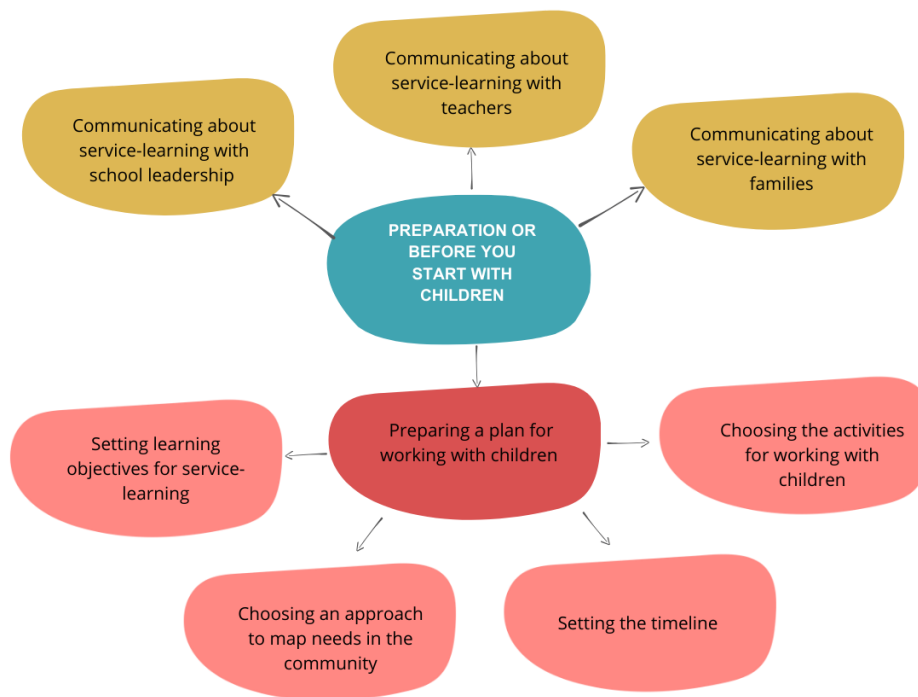

First, we offer you some tips on how to communicate about service learning with different groups.

### 1.1. Communicating about service-learning with school leadership

Suppose a school is to become a place where a child or young person can engage in community activities. In that case, the school leadership must be familiar with and ideally identified with service-learning. So, how do you explain to the leadership why the school should start with service learning?

### Arrange a time and place.

Arrange a separate meeting time and place with the school management to introduce service learning.

### Choose the appropriate form of communication.

You can prepare a short presentation; a video of a project you have already done or a concrete example is good. Good examples also from primary education can be found here:

<https://rslaward.eu/category/good-practices/>

[https://rootsandshoots.org/projects/?archive-s=&zip=&theme=&type=k-12-school&age-level=5-to-7-years&is\\_complete=](https://rootsandshoots.org/projects/?archive-s=&zip=&theme=&type=k-12-school&age-level=5-to-7-years&is_complete=)

<https://www.zerbikas.es/banco-de-experiencias/>

### Talk about the benefits for the school and the pupils.

Think about why the school should support the inclusion of service-learning. Consider your school's goals and what goals a service-learning strategy could help achieve. Here are some of the benefits that are research-documented and that you can use:

- **Strengthening links with the community** and building relationships with local organisations
- **Increase the school's visibility.** A school that actively contributes to the local community builds a positive reputation. Families, residents, and businesses begin to see the school as a centre important for education and community development.
- **The development of pupils' knowledge, skills and competencies, which the school supports.** For example:
  - Developing civic competencies and engagement: For example, if pupils take part in a project where they take care of the school garden and contribute to environmental activities in the neighbourhood, they learn responsibility for the world around them and the importance of contributing to the common good.
  - Promoting soft skills development: Service-learning projects are often about teamwork, helping students develop communication, collaboration, and conflict resolution skills that the school values as an institution.
  - Improving academic performance. When schools incorporate service learning into subjects like science or civics, students can better understand the curriculum through real-world applications. For example, the curriculum becomes more meaningful when they study environmental conservation in a biology course while participating in environmental projects.
- **Increased pupil motivation:** Service-learning often leads to increased motivation as pupils see the immediate impact of their work. For example, if they help to improve the school playground, they feel pride in the results and have a more positive attitude towards the school as a place where they learn and create.
- **Improving the school environment and school climate.** Projects where pupils work together to improve the school or its surroundings, such as landscaping the schoolyard or organising community events, can improve relations between pupils, teachers and school management.

- **Prevention of negative behaviour.** Active involvement in socially beneficial activities can reduce bullying and other inappropriate behaviour as pupils develop empathy and become more aware of the needs of others.
- **Increase the school's attractiveness.** Schools that offer innovative programs such as service learning can attract more teachers looking for a meaningful and creative environment in which to work. They can also attract families who want a learning program for their children focusing on hands-on experiences and community engagement.

## 1.2. Communication with other teachers about service-learning

A pro-volunteer or pro-service-learning school atmosphere is ideal, and creating it is a long-term process. This means it does not come from nothing, only from the constant intervention of someone in the school. A positive perception of service-learning and, consequently, support from teachers is critical, and without it, service-learning is more challenging to promote. Answer: "How to overcome the possible negative attitude of teachers" or the frequent opinion, "It does not concern me..." is best sought in the light of knowing your colleagues.

### Tips on how to go about communicating with teachers about service learning:

- **Provide background information** on this strategy - what it consists of and the key characteristics.
- **State the benefits of service-learning** for the pupils, the school, the links and the connection to the school's existing documents.
- **Involve teachers** in getting to know the community; they can help find and suggest opportunities or community needs.
- **Appeal to new trends in education** - experiential learning to develop civic competence or critical thinking.

## 1.3. Communication about service-learning with families

Communication with families before implementing the service-learning project is also vital. The types we offer for communication with this target group have been developed based on the manual on education for volunteering, Pathways to Volunteering; we apply them to service-learning (Brozmanová Gregorová et al., 2019). Activities outside the school must always be carried out in primary education only after informed consent and agreement with the pupil's legal representative. Families are the ones who can enthuse pupils for activities in the community but, on the other hand, also hinder them in these activities. It is, therefore, essential to provide them with as much information as possible. Ideally, involving families in planning and implementing service-learning projects would be best.

- Before the meeting with families, **have an idea of how you would like to develop service learning at your school** and integrate it into your teaching.
- At the meeting with families, you should **inform them what service learning is, why your school is involved in this type of activity, what it means for pupils and how it will benefit**

**them.** Talk to them about the possibilities of activities the pupils choose - that the school is open to children's initiative and will support them in their community activities.

- Explain to families that **the projects you plan to engage in with their children are part of the educational process and that children learn through this experience.** Children can apply their knowledge, skills, experience and talents. Reassure families that the bottom line is always that pupils learn something new. Through service learning, pupils can not only improve in a particular learning area, but they will also develop their ability to work with others, be more motivated to learn, develop responsibility, be better able to make decisions and solve problems. Talk to them also about the benefits for the community in which they live, promoting solidarity, responsibility, etc.
- **Give specific examples of projects and activities implemented.** Use the list in the previous section of the toolkit.
- If there is even one parent, volunteer or service-learning enthusiast in the class, **invite** them to give their reasons for joining in and to support you as a teacher in implementing this strategy.
- If there are families who, despite explanations and examples of good practice, will have a **negative attitude** towards service learning, point out to them that the child builds a relationship with the whole class, strengthens relationships, gets into a particular social role, and the parent's disagreement with the child's involvement in the activity can harm him/her. You can also offer them the opportunity to suggest an activity that they feel is appropriate for the pupils and that they think would be beneficial for their child. You could also consider involving the parent in some of the activities, which many families might welcome, and the barrier of ignorance and certain myths about service learning would disappear. Accept family feedback and discuss the issues and inconsistencies that arise with them. Ensure that families are given the most accurate and precise information about your service-learning project, its benefits for their children, and how they can be helpful as families.

#### 1.4. How to prepare a plan for working with children

To communicate with the management, colleagues, and families, but also with children, you need to prepare a preliminary plan for working with children in advance. In service-learning, it is only possible to plan some things precisely in advance because your plan may change depending on what the children are interested in, what they choose as a need they want to address, or how you implement what you have planned. However, we recommend following the rule of improvisation: only those who have a plan can improvise.

When planning to implement service learning in your work with children, think about:

1. What learning objectives do you want to achieve by implementing service-learning?
2. What approach will you take to **mapping needs in the community?**
3. How much **time** will you allocate for service-learning implementation?
4. How will the pupils be **prepared to implement** service-learning activities?

5. How will **the planning of the** service-learning project take place?
6. How will you do **reflection** with your students?
7. How will you **evaluate the** implementation of service learning?
8. How will you **monitor** the implementation of the service-learning project?

In this chapter, we address the first three points. Tips for answering questions 4 to 8 can be found in the following sections of the toolkit. The questions are always accompanied by practical activities and tools you can use.

### 1.5. How to set learning objectives in service-learning

In service-learning, the learning and service objectives must be linked together. This will be successful for you as a teacher if you are clear about the learning objectives you want to achieve, i.e. if you define what specifically the children should learn through the service-learning. Later, when it is clear what need or problem the service-learning project will address, you will set the service goals with the children. Since service-learning projects are about solving practical problems and the world is not made up of specific subjects, the learning objectives of service-learning relate to several areas of learning, or you can develop several literacies within them, for example, reading or visual literacy, digital literacy, financial literacy, civic, media and intercultural literacy, environmental literacy or social and emotional literacy. At the same time, in service-learning, you cannot predict everything from start to finish and children may learn what you did not intend initially. So, you can gradually add to and reflect on the objectives.

In the beginning, however, you need to define what the children need to learn, just as you do when planning traditional lessons or your education plan. The learning objectives will depend on the year group of the pupils you will work with and the curriculum frameworks of your country or school. So you do not need to “invent” learning objectives - you already have these planned, look at what the children are expected to learn in a given year, what they are expected to know at the end of the year, for example. Of course, you will not be able to achieve all the learning objectives with service-learning, nor will you probably link it to all the subjects, but here is a list of objectives you can work with. Analysing the needs of the pupils or class can also help you define your objectives. For example, if you would like pupils to work more collaboratively with each other, link this to a learning outcome, such as pupils working collaboratively with others to solve problems respecting different approaches to solving.

We recommend that, even in the case of primary education, you choose at least the primary area where you would like to use service learning. For example, this could be in science, nature or literacy development. See the project types in the previous section related to each area. Consider what subjects you can link the implementation of service learning to. You can define the objectives of service-learning within each literacy domain that primary education intends to address.



It is ideal to set a learning objective and a performance standard, i.e., what the pupil should know at the end of the learning. We, therefore, offer some examples of learning objectives that service-learning projects can meet, along with performance standards, for inspiration. We were inspired by the objectives defined for primary education in the second cycle (4th-5th year of primary school), which are part of the education reform in Slovakia and [part of the state education programme](#).

When working with children, involve them in planning learning objectives. They can each set out what they would like to learn in the project and set it out as a group. You can then add these to your learning objectives or highlight them.

**Table 5: Examples of learning objectives for service-learning projects in primary education**

Educational area	Learning objectives	Performance standard: The pupil can:
Language and communication (primarily reading and visual literacy)	Conduct dialogue in private and public settings in a substantive and socially appropriate manner.	<ul style="list-style-type: none"> <li>• communicate respectfully with classmates from multilingual backgrounds,</li> <li>• conduct the dialogue in a way appropriate to the topic, the addressee and the communication environment,</li> <li>• initiate and lead communication in a peer group,</li> <li>• express an opinion on a standard or topical issue, justify it or modify it,</li> <li>• respect the opinion of the communication partner,</li> <li>• express approval, praise, appreciation, objection or disagreement in a socially appropriate manner</li> </ul>
	Prepare and deliver an appropriate spoken speech.	<ul style="list-style-type: none"> <li>• make a simple speech,</li> <li>• modify the content and language of the spoken speech,</li> <li>• listen actively and respectfully to the spoken discourse of others, asking questions about the content and language of the discourse</li> </ul>
	Produce written and pictorial texts to express various communicative intentions and apply learned spelling rules in writing texts.	<ul style="list-style-type: none"> <li>• produce a coherent written or pictorial text on a chosen topic,</li> <li>• gather the necessary information to produce a written text,</li> <li>• express your feelings and imagination through writing,</li> <li>• edit the content, composition and language of the written text,</li> <li>• apply graphic skills in editing the formal aspects of a written text</li> </ul>
	Express ideas and suggestions in the creation of texts and ask questions about the submitted proposals.	
Mathematics	Collect, record, organise and sort data; find appropriate data organisation; create	<ul style="list-style-type: none"> <li>• collect real-life and contextually relevant data from observation, measurement or simple experiment, present it using frequency tables,</li> </ul>

(primarily numeracy and financial literacy)	simple frequency tables and graphs; and interpret results	graphs and arithmetic averages, and interpret real-life data in simple contexts
Informatics (primarily digital literacy)	Get familiar with tools for working with text, graphics, presentations, audio and video.	<ul style="list-style-type: none"> <li>• use specific tools to create and edit images, animations, text, stories and slideshows and to trigger sounds and video,</li> <li>• combine graphics of different types and from other sources,</li> <li>• choose the appropriate tool for working with text,</li> <li>• use tools to find and replace text,</li> </ul>
	Acquire, retrieve and process information of various types.	<ul style="list-style-type: none"> <li>• search and retrieve information in the information system and database,</li> <li>• extract information of different types using specific tools,</li> <li>• select appropriate information processing tools,</li> </ul>
	Navigate safely in a digital environment.	<ul style="list-style-type: none"> <li>• discuss the ethical use of digital products,</li> <li>• discuss dangerous applications,</li> <li>• discuss the use of specific digital technology tools in learning other subjects</li> </ul>
Man and nature (primarily environmental literacy)	Link your current science ideas and findings to their responsible, sustainable, practical and technological application.	<ul style="list-style-type: none"> <li>• Acknowledge human dependence on natural resources,</li> <li>• reflect on their daily habits in the light of knowledge about healthy lifestyles,</li> <li>• be aware of the level of responsibility for your health and the health of others,</li> <li>• respect health and safety principles at work,</li> <li>• realise the benefits and importance of science and technology.</li> </ul>
	Reflect on one's cognitive process, which aims to find explanations for observed phenomena and whose explanations must be supported by relevant data.	<ul style="list-style-type: none"> <li>• see their (research) activities as one of the sources of new knowledge,</li> <li>• Recognise inconsistencies/errors in the results obtained from the observation and identify their causes,</li> <li>• objectively evaluate their work and the work of their classmates</li> </ul>

	<p>Propose partial solutions to simple natural, environmental or technical problems and justify these solutions with their knowledge. Assess not only the functionality but also the effectiveness (economic, environmental, etc.) of different solutions to local problems.</p>	<ul style="list-style-type: none"> <li>• consider decisions with less negative impact on the natural environment,</li> <li>• evaluate the reasons for nature conservation,</li> <li>• Identify activities aimed at protecting and improving the wider environment of the school and village/town,</li> </ul>
<p>Man and society (primarily civic literacy and social and emotional literacy)</p>	<p>To develop the uniqueness of the self, to name the basic components of one's identity and one's social roles, to exercise a respectful attitude towards others</p>	<ul style="list-style-type: none"> <li>• Name the contribution of their unique characteristics to others (peer group, community),</li> <li>• apply respect concerning others and identify stereotypes in their evaluation of others,</li> <li>• describe the social roles with which he/she identifies and know the social roles expected of him/her,</li> <li>• create and maintain positive interpersonal relationships with people in the neighbourhood who have different needs (at school - in the local community),</li> <li>• to know local and regional cultural and social realities and history and their importance in the construction of one's own cultural identity.</li> </ul>
	<p>Communicate constructively and with respect for pupil belonging and cooperation.</p>	<ul style="list-style-type: none"> <li>• Have a respectful, appreciative and constructive dialogue with others,</li> <li>• communicate using simple, factually correct reasoning,</li> <li>• to draw out and apply the principles of good cooperation,</li> <li>• apply empathy and assertiveness in relationships with people in the environment,</li> <li>• understand that multiple perspectives can exist on events, phenomena, processes and persons.</li> </ul>
	<p>Understand the meaning and importance of rules, responsibilities and exercising rights as a community member.</p>	<ul style="list-style-type: none"> <li>• recognise rights and responsibilities from the perspective of a resident of the municipality,</li> </ul>

		<ul style="list-style-type: none"> <li>• Respect the rules in force in the school and the community and demand their observance,</li> <li>• explain the role of authorities, institutions, and civic initiatives in the village and its surroundings using concrete examples,</li> <li>• to justify the role and importance of representative democracy using the example of the pupil parliament and municipal government,</li> <li>•</li> </ul>
	Actively engage in activities to improve the functioning of the school and the community	<ul style="list-style-type: none"> <li>• in collaboration with others, design and carry out an activity to solve a selected problem in their neighbourhood or an activity to help others promote solidarity and the common good</li> </ul>
Man and the world of work (different literacies and initiative and entrepreneurship)	Implement a practical and helpful idea.	<ul style="list-style-type: none"> <li>• make a selection of the most suitable idea to be implemented,</li> <li>• establish an implementation schedule, control and evaluation system to ensure that the work is completed by the deadline,</li> <li>• identify the materials and other aids needed to implement the idea,</li> <li>• accept and agree on different roles when working in groups,</li> <li>• to take their share of responsibility for working together,</li> </ul>
	Manage resources responsibly when working and producing products.	<ul style="list-style-type: none"> <li>• behave responsibly in managing money, including in determining the financial costs of the project</li> </ul>
Art	Creatively use tools, materials, media, techniques, technologies and practices to express their own ideas, fantasies, thoughts, experiences and feelings.	<ul style="list-style-type: none"> <li>• express their own thoughts, experiences, feelings, emotions, and imagination through the conscious choice of artistic means of expression and their combination,</li> <li>• Targeted use of tools, materials, techniques, technologies,</li> <li>• use simple digital technologies and tools for visual communication,</li> <li>• present the results of the creation</li> </ul>
	Reflect on the creation process and its results, respecting expressions of cultural diversity.	<ul style="list-style-type: none"> <li>• reflect and respect the process of creation and the creation of others</li> <li>• respect cultural diversity and its manifestations</li> <li>• work cooperatively and with respect for others in a group</li> </ul>



	Express and name different feelings and emotions.	<ul style="list-style-type: none"><li>• name and express feelings and emotions,</li><li>• name, share and respect different personal values</li></ul>
Health	Identify the negative impacts of addictive substances.	<ul style="list-style-type: none"><li>• recognise the dangers of addictive substances and their negative impact on human health</li></ul>



**Teacher Worksheet:**  
**Preparation 1: My service learning goals for this year**

Field of education/ subjects	Learning objectives	Performance standard

## 1.6. What approach to take to mapping needs in the community or where to map needs

There are several possible approaches to needs mapping, which is an essential step in service learning:

1. **Mapping within the school.** Service-learning projects can also be implemented within the school, although outreach outside the school is a more recommended practice. However, sometimes teachers choose activities that respond to the needs of the school or its immediate environment when they first experience them and only later decide to implement projects in an out-of-school setting. The disadvantage of this approach is that it provides less space for developing relationships within the community and outside the school and understanding the diverse contexts of the issues.
2. **Working with a specific community partner and responding to their needs.** This approach is based on the teacher selecting a particular organisation to implement the service-learning project. Usually, this is a partner with whom the school has been working for a more extended period on other activities or with other pupils. Sometimes service-learning projects are created when the school is approached by an organisation for cooperation, so that the initiative starts on the other side. Here, there may be a risk that the children will not be interested in being with the partner or working in the area the partner is involved in. For example, a long-term partner may be an organisation that provides services to seniors, but the children would like to work outdoors. However, the advantage is the development of long-term and reciprocal partnerships, which are essential for service-learning. For the children, the collaboration may occur in one school year, but working with your school may mean a long-term programme for the organisation.
3. **Mapping needs in the broader community outside the school.** This approach may be more challenging, but it allows for insight into the diverse needs or issues and, consequently, the different groups or organisations in the community and provides greater scope for pupil choice. Of course, again, you can guide the children on what issues to focus on or what area to map so that you can then link the project to the learning objectives.



**Worksheet for teachers**

**Preparation 2: My approach to needs mapping**

Approach to mapping	Yes/No	Why (give reasons for your choice)
Mapping in school		
Working with a specific community partner and responding to their needs		
Mapping needs in the wider community outside the school		



### **1.7. How much time to allocate for service-learning implementation?**

You can choose different lengths of time to implement service learning, but be sure to allow enough time for each phase. The size of the project depends mainly on the learning objectives and the need or problem you will be addressing with the children in the project. The ideal projects last the whole school year. Service learning becomes an integral part of education and contributes to longer-term change, not only on the side of the children but especially on the side of the community. However, we offer a variety of timetables set for different numbers of months.

Of course, the timetable also needs to be adapted to the school year. So, you can start at the beginning or middle of the school year.

Table 6: Service-learning implementation timelines				
Short project for 3 months	Medium project for six months	Project for ten months	Step	Outputs
The first month	The first month	The first month	Inspiration and motivation	Pupils are inspired and motivated to implement service learning and make a difference. Pupils set themselves what they would like to learn in the project Pupils agree on rules for group work
First to the second month	The first to the second months	The first to the third months	Project Planning - Community Needs Analysis	Pupils are aware of the specifics of the community and their needs and problems
The second month to the third months	The second month to the third months	The second month to the fourth months	Project planning - setting service goals	Pupils set up service objectives in service-learning projects connected with the learning objectives
	The third month to the fifth months	The third month to the eighth months	Planning other parts of the project	Pupils set up the plan for their projects
Third month	Fifth months	Night months	Evaluation	Pupils evaluate the impact of the project and what they achieved
	Sixth months	Tenth months	Celebration	Pupils reflect on their project and celebrate the success
From the first to the third months	From the first to the sixth months	From the first to the tenth months	Reflection	Pupils reflect on their experiences and learning
			Promotion	Pupils promote the project, activities and results
			Monitoring and documentation	Pupils document the project





## Worksheet for teachers

### Preparation 4: Checklist before working with children

<b>Management support</b>	Have you received guidance for implementing service learning with your class?	Yes/No
<b>Support from colleagues</b>	Have you explained to your colleagues what you plan to do with the children?	
	Have you gained the support of your colleagues?	
<b>Parental support</b>	Have you explained to the families what you plan to do with the children?	
	Did you get your family's support?	
<b>Learning objectives</b>	Have you identified the key learning objectives for your service-learning project?	
<b>The idea of mapping</b>	Have you chosen which needs mapping model you will choose?	
<b>Timetable</b>	Have you chosen a timetable for the implementation of service learning?	
<b>Preparation of pupils and pupils</b>	Have you planned how you will explain to the children what they will do and how their preparation will go?	
<b>Planning a service learning project</b>	Do you know how the needs mapping with the children and the planning of the service learning project will take place?	
<b>Reflection</b>	Do you have activities planned for reflection with the children?	
<b>Monitoring</b>	Do you have a plan for how you will monitor the project and track its progress?	
<b>Evaluation</b>	Do you have an idea of how you will evaluate the implementation of the project and how you will assess or grade the children?	

## 2. List of activities in each phase of work with pupils

Stage	Activities	Reflection	Monitoring and documentation	Communication and promotion
Inspiration and motivation	<a href="#">Story of Help</a> <a href="#">Who helped who</a> <a href="#">Mini project helping hand</a> <a href="#">What is service-learning?</a> <a href="#">Service-learning pathway</a> <a href="#">Bridge – teambuilding activity</a> <a href="#">Tree monkeys – teambuilding activity</a>	<a href="#">My personal goal</a>	<a href="#">Our project album</a> <a href="#">Experience diary</a>	<a href="#">Developing rules for communication and cooperation</a>
Mapping the community	<a href="#">Community – what it means</a> <a href="#">Community mapping (version 1)</a> <a href="#">Community mapping (version 2)</a> <a href="#">Preparation for the community survey</a> <a href="#">Evaluation of the survey</a> <a href="#">Problem selection (version 1)</a> <a href="#">Problem selection (version 2)</a> <a href="#">Problem selection (version 3)</a> <a href="#">Problem tree</a>	<a href="#">We know who we are helping</a>	<a href="#">Our project album</a> <a href="#">Experience diary</a>	
Project planning	<a href="#">Introduction of the project cycle</a> <a href="#">Planning objectives for our project</a> <a href="#">Goal tree (project objectives planning version 1)</a> <a href="#">Crossing the bridge (project objectives planning version 2)</a> <a href="#">Who are the other players?</a>	<a href="#">Linking education and service goals with children</a>	<a href="#">Measuring project success</a>	<a href="#">Planning promotion of service-learning project</a>

	<a href="#">Steps to the project</a> <a href="#">Activity planning and timeline for service-learning project</a> <a href="#">Assigning responsibilities in the team</a> <a href="#">Service-learning project budget planning</a>			
<b>Action</b>	<a href="#">Meeting in the circle</a> <a href="#">Joint discussion on the conflict</a> <a href="#">Our new plan</a> <a href="#">Building a tower</a>	<a href="#">My weekly thoughts</a> <a href="#">Reflective group discussions</a> <a href="#">Presentation of my contribution to the project</a>	<a href="#">Our project album</a> <a href="#">Experience diary</a>	
<b>Evaluation</b>	<a href="#">Stickers for thinking - Final evaluation of the project</a> <a href="#">A look back at the project cruise</a> <a href="#">My place on board</a> <a href="#">Traffic lights</a>	<a href="#">Five fingers</a> <a href="#">Drawing how I helped</a> <a href="#">Painting my feelings after helping others</a> <a href="#">Collage of what I learned</a> <a href="#">Wall of reflection</a> <a href="#">Feelings in the Rainbow</a> <a href="#">Project on wheels</a> <a href="#">A picture is worth a thousand words</a> <a href="#">Drawing a memory</a> <a href="#">What I brought, what I took away</a> <a href="#">From the top of the mountain</a>	<a href="#">Our project album</a> <a href="#">Experience diary</a> <a href="#">Summary of project experience</a>	<a href="#">Summary of project experience</a>
<b>Celebration</b>	<a href="#">Gallery walk - planning the final event</a>			<a href="#">Group photo of participants</a>

### 3. Introductory activities - laying the groundwork for service-learning

Before the children start mapping needs and planning a specific project, it is essential to make some input into the topic or methodology you will be working with. As a result of this input, the children should have a basic understanding of what is involved in being motivated to participate in the project; their own development goals should be named, and standard rules for working in a team should be established.



For instance, this year, you can collaboratively decide with the children how to monitor the project's progress individually and as a group. Individually, children can start keeping their diaries or portfolios using our workbook for children. You can agree on a collective monitoring approach and assign roles as a group, fostering a sense of responsibility and involvement. See the monitoring activities.

#### 3.1.1. How to explain what service-learning is or how to inspire and motivate pupils

The aim of the introductory activities with children when implementing service-learning is for children to understand the concept of learning by helping others and to be motivated to engage in such activities. By reiterating the goal, the children will feel clear and focused on their learning objectives. It is not about ensuring that the pupils understand all the principles of project implementation or master the steps of service-learning in depth. That is for the teacher or the teacher who works with them to know. Instead, it is about them being able to imagine the path that awaits them and being positive about embarking on it.

Introductory activities with children should be engaging, interactive and age-appropriate. We offer you some ideas that you could use.

## ACTIVITY: STORY OF HELP

**Aim:** The activity shows children that even minor deeds can make a big difference and that helping others can be fun and rewarding. The children will feel excited and eager to participate by emphasising the fun and rewarding aspects. Children will understand that everyone can contribute to improving their environment, even with small but sincere acts. At the same time, the activity introduces the children to what lies ahead.



**Materials needed:** A story or fairy tale about a child who helps someone in their neighbourhood (can be in print or oral form), illustrations or pictures (optional) to support the story, paper and coloured pens/pencils for each child, flipchart or whiteboard to write down key points.

### Procedure for the teacher:

**Introduction:** Start by discussing what it means to help someone. Ask the children questions such as: "Have you ever helped someone? How did that make you feel?" Let them share their experiences to create a comfortable atmosphere.

**Storytelling:** Prepare a story about a child who decides to help someone in their neighbourhood. The story could be about a boy or girl who, for example, allows an elderly neighbour to shop, a classmate with their homework or organises a litter pick in the park. When telling the story, make sure that the story is engaging and understandable to children in Key Stage 1. Include the emotions and feelings of the characters so that children can empathise with the situation. If you have illustrations or pictures, use them to visualise the story better.

**Discuss the story:** After the story, ask the children some questions for reflection:

- Why did the child decide to help?
- How did it feel when it helped?
- How did the person who was helped feel?
- What do you think the child has learned?

Discuss how the aid affected both the recipient and the provider. Encourage children to share their thoughts and feelings.

**Creative reflection:** Distribute paper and coloured pens or markers to the children. Ask them to draw or write a short story about how they could help someone. This could be something they would like to do or have already done. When the creative activity is finished, have the children present their stories or drawings to the others. Please encourage them to talk about why they chose this particular way of helping and how it made them feel.

**Conclusion:** Together with the pupils, summarise what you have learnt today and build on this theme by having them carry out a project in the following weeks/months where they will help someone and learn new things.

### Example story:

*Once upon a time, a little boy named Jacob was in the third grade of elementary school in a small town. Jacob was brilliant and curious, always trying to learn new things. In Jacob's neighbourhood there lived an old lady whom no one visited. She lived alone and always smiled kindly at him when*



*he met her in front of her house. He knew that Mrs. Novak had trouble walking. Jacob's mother sometimes helped her with the shopping. Once at school, she talked to the teacher about how everyone can do a good deed. Jacob wondered what he could do. So he knocked on Mrs. Novak's door. Mrs. Novak was shocked but also pleased. Jacob asked her if she needed help with anything. Mrs. Novak thought and said: "You know, Jacob, it would help me a lot if someone would help me clean up the garden. I don't have as much strength as I used to have."*

*Jacob offered to help her. After school he put on his old clothes and went to Mrs. Nováková's garden. He spent several afternoons there, gathering leaves, pulling weeds and planting new flowers with her help. They talked a lot as they worked, and Mrs. Nováková told him stories about her childhood, and Jacob learned many exciting things. After a few days, the garden was beautifully tidy, and Mrs. Nováková was very happy.*

## ACTIVITY: WHO HELPED WHO?

**Aim:** The activity 'Who helped who?' is designed to engage children's curiosity and encourage them to participate actively. They will realise that helping can take many forms and understand that everyone can contribute to improving their environment. The activity will help them recognise situations where they can help and learn from each other's experiences.



**Materials needed:** pictures or cards depicting different helping situations, a whiteboard or flipchart for writing down ideas, tape or magnets to attach the cards to the board (optional), paper and pens for children to take notes.

### Procedure for the teacher:

**Introduction:** Let's start with a thought-provoking question: What does it mean to help someone? Have you ever helped someone? How did you help, and how did it make them feel? Today, we will explore these questions and learn about different forms of helping and why it's important to help others.

**Presentation of pictures:** Show the children prepared pictures or cards showing different helping situations. For example, you can show the following situations:

A child assisting an older man carrying shopping bags

Child picking up trash in the park

A child who shares a meal with another child

A child helping a classmate with homework

A child helping mum with housework

Let the children look at each picture and think about what is happening.

**Group discussion:** divide the children into small groups (3-4). Give each group one or two pictures to discuss. Ask them to discuss the following questions:

- What is happening in the picture?
- Why is such help necessary?
- How would the one receiving help feel?
- How would the one providing the help feel?

Please encourage them to collaborate and share their ideas.

**Sharing findings:** Each group then presents its picture to the rest of the class and tells what they discussed. Write the critical ideas on the board or flipchart. You can ask other children if they have any additional ideas or experiences to add to the shared ideas.

**Summary and reflection:** together summarise what you have learned. Emphasise that help can take many forms - doing big things to help someone is unnecessary. Ask the children, "What do you think is the most important thing about helping others?" and "How can you help someone today or in the next few days?" Encourage children to think about how they can help others daily, whether at home, school or in their community. Extend the activity by creating a collaborative bulletin board to display all the cards and ideas the children have discovered during the activity. This bulletin board can serve as inspiration for future service learning activities.

## ACTIVITY: MINI-PROJECT HELPING HAND

**Aim:** To strengthen children's commitment and responsibility to help others by creating a symbolic pledge they will always keep in sight.



**Materials needed:** coloured paper (large enough to trace a hand), scissors, coloured pens, markers or crayons, sticky tape, string or pins for hanging, bulletin board or space to hang the paper hands

### Procedure for the teacher:

**Introduction:** Explain to the children that we can help others in different ways—at school, at home, or in the community. Ask them to think about how they would like to contribute.

**Making paper hands:** Distribute coloured paper and ask the children to trace their hands and cut them out. On each paper hand, children write or draw a specific way they can help someone. For example, it could be helping with homework, cleaning a common area, giving time to an older adult or picking up litter in the park.

**Sharing and hanging paper hands:** When the children have finished their paper hands, they can share their ideas with the rest of the class. Then, they can hang all their hands on a bulletin board or other visible place in the classroom. This way, their commitment to helping will be ever-present and visible.

**Conclusion:** emphasise that the paper hands on the bulletin board are not just decoration but a symbol of their commitment to help. Encourage the children to try to do what they set out to do and to notice opportunities to help in their environment. Explain what awaits them in a service-learning project.

## ACTIVITY: WHAT IS SERVICE-LEARNING?

**Aim:** To introduce the concept of service learning through videos so pupils can better understand what it means and get inspiration for their projects. The activity is designed to show children that learning can be linked to helping others and that they, too, can contribute to improving their environment.



**Materials needed:** projector or interactive whiteboard, prepared videos on service-learning or examples of successful projects suitable for primary school children, paper and coloured pens/pencils for reflection, whiteboard or flipchart for writing down ideas

### Procedure for the teacher:

**Introduction:** Start with a short discussion in which you explain the basic idea of service learning: combining learning with helping others.

**Video slideshow:** Show the children selected videos showing service-learning projects. After each video, pause to give the children time to reflect on what they have seen. For example, the videos can be found here: <https://rslaward.eu/category/good-practices/>

**Discussion about the videos:** After watching the videos, open a conversation by asking students for their impressions: 'What did you like about the videos?', 'Why do you think these kids did what they did?', 'How do you think they felt when they helped?' On the board or flipchart, write down the critical thoughts and ideas that the children express.

**Creative reflection:** After the discussion, give the children paper and coloured pens or markers. Ask them to draw or write what they want to do in service learning. This could be an idea for a project they would like to carry out or a specific help they could offer. They can share their ideas with the rest of the class.

**Summary:** Summarise what the children have learned about service-learning today and encourage them to think about how to turn their ideas into reality.

## ACTIVITY: SERVICE-LEARNING PATHWAY

**Aim of the activity:** to use an illustrated map to familiarise pupils with the different steps of service-learning and to give them an overview of what they can expect in their project. The activity aims to show children that service-learning is a process that involves several steps, from planning to celebrating successes.



**Materials needed:** illustrated map of the steps of service-learning (which can be projected on the board or given to the children in printed form), paper and pens for children to take notes, coloured markers or crayons

### Procedure for the teacher:

**Introduction:** Start with a short discussion with the children, explaining the basic idea of service-learning: combining learning with helping others. Use a simple example, such as how assisting a classmate with their learning can benefit both parties.

**Presentation of the map:** Present an illustrated map of the steps of service-learning to the children. Show them that the map represents the "path" they will follow during their project. Go through the steps on the map one by one and explain what each step means:

**Preparation and planning:** Children map the needs and problems in their environment, then think about what they would like to achieve and make a plan.

**Implementation:** Children start to implement their ideas and projects.

**Reflection:** During implementation, they reflect on what they are learning and how they are doing.

**Monitoring and evaluation:** They monitor their work progress and what they could improve.

**Closure and celebration:** At the project's end, they will enjoy their achievements and celebrate their work together.

**Map discussion:** After explaining the map, discuss it with the children. "Which step do you find most interesting?", "What are you most looking forward to?" "What would you like to learn during this project?" Write critical thoughts and ideas on the board or flipchart.

**Creative reflection:** divide the children into small groups and let them create their version of the map. Each group can express which step they found most exciting or important. When finished, have each group present their map and explain why they chose a particular step.

**Summary:** Summarise what the children have learned about service-learning today. Please encourage them to think about how to turn their ideas into reality.



### 3.1.2. How to set personal development goals with pupils

In service-learning, the teacher sets the learning objectives, but it is great if the children can choose what they want to develop. They do not have to make a whole list; they must choose one thing they want to improve or learn.

#### ACTIVITY: MY PERSONAL GOAL

**Aim:** Children will realise the importance of setting personal learning goals in service-learning and can choose one thing they would like to improve or learn. The activity also promotes self-awareness and developing responsibility for their education.



**Materials needed:** paper cards (or papers cut into smaller pieces), coloured pens or markers, a bulletin board or space to hang the cards, tape or pins to attach the cards to the bulletin board

#### Procedure for the teacher:

**Introduction:** Start by discussing with the pupils what service-learning is and how important it is to help others and learn something new. Explain that with this type of learning, it is great if everyone can choose an area they would like to improve or learn.

**Explain the activity:** Explain to the children that today, they will have the opportunity to think about what they would like to improve or what new things they would like to learn. This could be something that will help them at school, at home, or in helping others.

**Individual work:** Distribute cards and coloured pens or markers to the children. Ask them to write something they want to improve or learn on the card. For example, they can improve in math or reading, work better with others, focus better on tasks, or more. If they want, they can also draw a small picture on the card that describes their goal.

**Sharing goals:** If the children are willing, let them share their goals with the rest of the class. Everyone can come to the class and read or show what they have written on the card. Encourage others to show support and encouragement to everyone.

**Goals board:** When the sharing is finished, ask the children to attach their cards to the prepared bulletin board. Explain that this bulletin board will serve as a reminder of their personal goals, and they can refer back to it throughout the service-learning period. They can also write them in their workbooks.

**Reflection:** At the end, ask the children how they felt about setting their goal and what might help them achieve it. Encourage them to keep their goal in mind and try to achieve it, even though it may be difficult.

**Follow-up:** Refer back to the board continuously to monitor children's progress towards their goals. You can discuss with them what is helping or getting in the way. If possible, integrate these personal goals into other service-learning activities so that children see the connection between what they want to learn and what they have to offer others.

### 3.1.3. Rules and teamwork

Teamwork is essential in a service-learning project. Your class has probably worked together for a long time, and you do not need team-building activities. Still, these activities allow you to explain well afterwards how important it is to have some rules during the project and to set them in the next activity, but also to understand how important it is to divide the responsibilities in the team and that some roles in the project will be given to the teachers and some to the children.

## ACTIVITY: BRIDGE - TEAM BUILDING ACTIVITY<sup>1</sup>

**Aim:** To develop pupils' teamwork skills, strengthen non-verbal communication and increase their listening skills.



**Materials needed:** scissors, sheets of paper, pencils, paper cup, cardboard, glue, open space (e.g. hallway or large room) to keep the two teams separate

#### Procedure for the teacher:

**Teaming and introduction:** Divide the pupils into two teams. Each team will build a part of the bridge that complements the other team's part. Explain the rules of the game. Emphasise that team communication is limited and can only occur during regular team leader meetings.

**Team leader selection:** At the start of the game, each team selects a team leader to represent the team and communicate with the other team leader. The leaders will meet every 5 minutes for a short meeting to discuss their team's progress and coordinate bridge building. Leaders may use verbal communication during these meetings; otherwise, verbal communication is prohibited during construction.

**Building the bridge:** each team works on its part of the bridge using the assigned tools (scissors, paper, cardboard, glue). The goal is for the bridge to hold a paper cup full of water. The teacher regularly checks progress and ensures that the rules and time limits for the leaders' meetings are followed.

**Bridge strength test:** When time is up, both teams bring their parts of the bridge to the centre of the room and try to join them into a whole. The teacher will test the bridge's strength by placing a paper cup full of water on it. The goal is for the bridge to hold the cup without falling off.

#### Debriefing and reflection:

Organise a debriefing after the activity. Sit the children in a circle and ask them to share their experiences. You can ask the following questions:

- How did you feel during the activity?
- What do you think about communication within the team?
- How do you evaluate the cooperation with the other team?
- How did you perceive the role of the leader?
- What problems did you have with communication, and how did you solve them?

<sup>1</sup> Centre for European Volunteering. (2022). [Service learning upscaling social inclusion for kids – Toolkit](#).



**Observation:** During the activity, observe each child's behaviour, cooperation, and ability to communicate nonverbally. It is essential to observe the dynamics of the teams and how they solve problems and challenges.

**Conclusion:** This activity not only strengthens the ability to work together as a team but also shows the pupils the importance of communication, trust, and the ability to handle challenges together. Point out that everyone has a role to play in the team. You can follow up on what rules were effective for teamwork and set rules based on that during the service learning project.

*Activity can be simplified for younger children by, for example, having the entire class building a bridge together (without dividing them into two teams) and maybe also removing the challenge of non-verbal communication.*

## ACTIVITY: THREE MONKEYS - TEAM BUILDING ACTIVITY<sup>2</sup>

**Aim:** To develop communication and collaboration skills among students and to recognise the importance of coordination and effective communication in problem-solving, even when limited resources are available.



**Materials needed:** paper and pencils for note-taking (one set for each group), a whiteboard or flipchart for writing down key questions and answers, and a pen for writing down answers.

### Procedure for the teacher:

**Grouping:** Divide the pupils into groups of three. Assign each group the task of planning a field trip to a place in or around the school. Explain the rules of the activity, stressing that each member of the group will have a specific role:

- **One can only listen:** This member may listen to what others are saying but may not speak or write anything down.
- **One can only see:** This member may see what others are doing without speaking or listening to anything.
- **One can only talk:** This member may speak and explain their thoughts but may not listen to the answers of others or take notes.

**Planning the trip:** Give students 7 minutes to try to plan the trip based on their limited communication skills. Each team member will need to contribute their part of the information so that the group can make a complete plan. Encourage them to try their best to discuss and answer questions about the trip, such as:

- Where are we going?
- How do we get there?
- What will we need for the trip?
- What is the goal of our trip?

**Results check:** when time is up, groups will present their trip plans to the class. Discuss how they were able to manage the task with limited communication skills. Each group should answer the following questions:

- Were you able to plan the trip?
- What was the most challenging part of this task?
- How did you work together as a team?

**Reflection:** Discuss what the pupils have learned during the activity. You can ask questions such as:

- How important was effective listening in this activity?
- How did you feel when you had limited communication skills?
- What would you do differently if you had another chance?

**Conclusion:** Summarise what the pupils have learned about communication and cooperation. Explain that success depends on working together effectively and listening to other team

<sup>2</sup> Centre for European Volunteering. (2022). [Service learning upscaling social inclusion for kids – Toolkit](#).



members, even if they have different abilities or limitations. Link the activity to the development of rules during the service learning project.

The activity might be simplified for younger children by introducing visual aids to explain each role and shorten the time frame (giving the students pictures of someone who talks, listens, and looks to assign roles). A simplified version might also allow a few minutes of accessible communication to help children complete the task.

You may have established rules for cooperation and communication in your classroom. Nevertheless, we recommend developing rules specific to the service-learning project with the children. They can reflect on what the pupils already know about service-learning, the plan, or what they would like to learn in the project. Establishing and following rules is one of the prerequisites for effective communication and collaboration. Rules also help to create a safe atmosphere in the group.

For service-learning to work correctly, pupils and teachers must respect the rules. The teacher's role is to ensure that the rules are followed. If, during planning or implementing service-learning, it becomes clear that the rules are not working, are not being followed, or are insufficient, revise them. Let learners discuss what is not working and why and suggest possible solutions.

## ACTIVITY: DEVELOPING RULES FOR COMMUNICATION AND COOPERATION<sup>3</sup>

**Aim:** The pupils will establish rules for communication and collaboration in implementing a service-learning project.



**Materials needed:** markers and flipchart.

### Procedure for the teacher:

**Introduction:** ask students what the rule is and what it is for. Have pupils list some rules that come to mind. For example, they might list school or class rules.

Introduce the pupils to the course and the aim of the activity. The pupils must know the activity's aim and what they must achieve. The project's communication and cooperation rules have been agreed upon. These rules will guide them through the whole project process.

**Making rules:** Divide the pupils into small groups and let them make rules for communication and cooperation. Give each group a flipchart divided into two parts: 1) what rules can help us to implement a service-learning project? 2) What other rules would we add? The group fills in the first part of the flipchart and creates at least three rules. The rules should be written positively ("What are we going to do..."). Give students 5-7 minutes for this part.

Swap the flipcharts between the groups and let the children fill in the rules they can still think of in the second part. These can be the ones they wrote on their first flipchart or new ones.

**Sharing rules between the group:** each group shares the rules created on both parts of the paper.

**Agree on standard rules:** Post the rules set in small groups in a visible place, and with the pupils, cross out those that are repetitive or irrelevant. Combine similar regulations into one. The groups should always agree to modify the rules. Set 4-6 standard rules.

Agree on what will happen if someone does not respect the rules. It is not necessary to set up a system of punishments or sanctions but rather to agree on how pupils can make it clear that a rule is not being respected.

Place the agreed rules in a visible place, and the children can also note them in their diaries.

**Reflection at the end:** you can discuss with the children at the end:

- Which rules were the easiest to agree on?
- Which rules were the most difficult to agree on?
- What helped you to create standard rules?

<sup>3</sup> Ambrozyová, V., Janičinová, B., Svatá, K., et al. (2019). *Metodika programu Active Cizizens pro 2. stupeň základních škol*. Člověk v tísni, o.p.s.

## 4. Mapping the community

In service-learning, mapping the community's needs is the beginning of the project planning journey. It is essential to guide children that in making changes or solving problems, it is not the idea or how we see the critical issues that matter, but the real need and what those affected say about it or how they perceive it. Needs mapping is also a prerequisite for doing activities with the community from the beginning, not just for it.



Needs mapping will vary depending on whether the community will be your school, what you will be implementing the project in an organisation you are already working with, or whether you will be mapping the community's needs around the school setting. Tailor the activities to the model you choose.

### 4.1. Before you take the kids into the field

Initially, it is good to explain to children what a community is. They may have already encountered the word but do not know precisely what it means, so it is ideal if children understand the concept themselves and realise what communities they are part of. Depending on the mapping approach you choose (school, organisation, community), you can then focus on a deeper understanding of the community the pupils will be helping. Knowing the community where you want to make a difference is critical to setting meaningful goals for the service-learning project and its implementation. Community mapping precedes the activity in which the learners go into the field to research and map real needs and problems. Before doing so, they should have the opportunity to reflect on how they perceive the community, realising that perceptions and relationships to place may vary from person to person. Pupils should also understand why it is essential to identify needs if we want to make a difference from the perspective of the people affected by the need or issue.

In this section, we offer tips for three types of activities. One explains the concept of community, and the other teaches about community and helps you become aware of the need to empathise with other people's needs or problems from their point of view.

## ACTIVITY: COMMUNITY - WHAT IT MEANS<sup>4</sup>

**Aim:** To learn the meaning of the term community and how it can be defined, to become aware of its diversity, and to name the communities they are a part of.



**Materials needed:** flipchart paper, sticky notes, writing utensils

### Procedure for the teacher:

Introduction: Ask students if they have encountered the term "community", and let them explain what they mean by the word. Fill in their definitions and give examples of communities. Internal bonds, cohesion, and solidarity with the outside world characterise a community. We can look at community from different perspectives:

- Geographically - a community is a group of people living in a familiar place (e.g. residents of a particular village, housing estate, or town)
- In terms of interests - a community is a group of people who share common interests, experiences, goals, and values (e.g. footballers, YouTubers)
- In terms of similarity or identity - a community is a group of people with the same identity (e.g. cultural) or other similarities (e.g. vegetarian, Christian).

Have students draw a community that is close to them. How do the pupils imagine it? Who makes it up? What is it for? How does it function? Then, have them present and summarise the meaning of the word community.

Examples of communities are the local football team, neighbours where you live, scout troop, parish, and local YouTubers.

Let children think about what communities they are part of. They can write each community on a separate piece of paper and stick it on a flipchart.

Summarise what a community is and what distinguishes it. Have children note critical ideas in their notebooks.

<sup>4</sup> Ambrozyová, V., Janičinová, B., Svatá, K., et al. (2019). *Metodika programu Active Cinizens pro 2. stupeň základních škol. Člověk v tísni, o.p.s.*

## ACTIVITY NAME: COMMUNITY MAPPING (VERSION 1)<sup>5</sup>

**Aim:** Pupils will become aware of their relationship to place and the different perspectives of the community in which they move. They will realise that the relationship to place can vary from one person to another. Pupils will create a map of their local community, marking areas that are important to them.



**Material needed:** Large sheets of paper, printed maps of the village, sticky notes, coloured crayons and markers

### Procedure for the teacher:

**Introduction:** Introduce the lesson topic and determine what size community you will be working with. Build on the previous activity where you explained what a community is and say that today you will be looking at the local community in which your school is located. In smaller communities, you can focus on the whole community; in more prominent places, define, for example, the neighbourhood in which the school is located.

Write down essential places in your community on the board together. Invite pupils to list the places important to the community (institutions, shops, meeting places, residential areas...). Write the answers on the board.

**Make a map of the community:** Divide the pupils into groups of about 5. Each group will be given a large piece of paper and pencils. The group's task will be to create a map of your community with its important places. For younger children, you can print out the map as a template.

Think about what the community has to offer. Ask the groups the following questions:

- What services and facilities can we use in the community? What does it provide to its members?
- What skills of community members can be used?

Students record their answers in groups on Post-it notes and place them on the map.

Think about how pupils relate to each place. Ask them to express their relationship to each place by using smiley faces, which they paint on sticky notes and place in the appropriate part of the map. If the pupils in the group are not together, stick on a sticky note for the group. They can assign more symbols to a place if they have different relationships. Invite the pupils to clarify in the group why they have chosen this symbol for the place. Draw the symbols on the board:

😊 A place I like, I like

😞 a place I do not like,

? a place I do not know,

! a place that I consider dangerous

<sup>5</sup> Ambrozyová, V., Janičinová, B., Svatá, K., et al. (2019). *Metodika programu Active Cizizens pro 2. stupeň základních škol*. Člověk v tísni, o.p.s.

+ a place that I find meaningful.

Create one common community map with the whole class. Spread all the maps around the class and let the pupils choose one to work with next. Tell them that this map now becomes the standard map of their class; they need to plot the opinions of the others on it. Gradually have the other groups add to the map if they want to add anything.

Go back to the map and the slips of paper where they recorded the symbols and essential services and skills of community members and ask questions:

- Why do positive comments surround some places on the map?
- Why are the comments elsewhere negative?
- Why does your relationship with each place differ?
- Why can people have completely different ideas about one place? (people have different needs and interests so that tensions can arise)

Conclusion: Explain to the students that the map is a collective picture of how you perceive your community. It is very likely that if a different group of people were creating the map, it would look different, and the perspectives of individual community members may differ. Remind students to keep this in mind as they plan their projects. Have the children write a short reflection on this activity in a journal. Photograph the map created; the children can file a miniature version in their journals.

## ACTIVITY: COMMUNITY MAPPING (VERSION 2)<sup>6</sup>

**Aim:** To help children understand different aspects of their community, including people, animals and the environment, to encourage cooperation and teamwork in creating a shared map of the community.



**Materials needed:** 3 sheets of paper for each group, flipchart paper or even more significant, pens, crayons, pencils, stickers, tape or glue, scissors, optional: children's books illustrating communities, magazines, newspapers, Lego or other building blocks

### Procedure for the teacher:

**Introductory Discussion:** In the introduction, explain to the children that their task will be to explore the different parts of their community and categorise them into three main areas: people, animals and the environment. Discuss what makes up a community and provide some examples to help children better understand the concept of community.

**Group brainstorming:** Divide the children into groups and give each group 3 sheets of paper. Invite them to brainstorm and categorise in groups using the following questions:

- **People:** Who lives in our community? What do they do for fun? Where do they learn and work? Where do they get their food? Where do they go when they need help?
- **Animals:** What animals live in our community? Are they pets or wild animals? Where do these animals live, and where do they get their food?
- **Environment:** What are the environmental features in our community? What kinds of plants grow here? Where does our community get its water from? Where do we play when we are outside?

Each group should draw their ideas on paper, label and cut out each drawing.

**Creating a map:** Imagine that everyone is a bird flying over their community. On a large piece of paper or poster paper, the group draws a map of their community or has them prepare the map ahead of time. Children work together to glue their drawings of people, animals and environmental features onto the map. Discuss how the map becomes a jigsaw puzzle and how each drawing is essential. Use the following questions to guide the discussion:

- Where do the animals live on our map? Where do they get their food? Where do they sleep?
- How do people in our community help each other?
- Why are plants important in our community? What do you notice about them?

**Reflection:** After completing the map, let the children reflect on what they have learned during the activity. Set aside 5 minutes to lead this reflective activity. Allow children to turn to the person next to them and share their experiences. Then, the group reconnects, and volunteers are invited to share with the group:

- One new thing they learned about their community.
- How they feel in their community after mapping it.
- One thing they would like to do to help their community.

<sup>6</sup> Roots and Shoots. (2017). [Roots and Shoots Toolkit](#).

**Activity Alternatives:**

**Creative methods:** Instead of drawing, children can cut out pictures from magazines or newspapers or use Lego or other building blocks to create a model of their community. They then place these pictures or models in appropriate places on the map.

**Individual map:** The children first work together to make a list of people, animals and environmental features in their community, and then each draws their map that includes all the elements on the list.

**Extended discussion:**

Once you have completed the map, you can lead further discussion, focusing on questions such as:

- What do you like about our community?
- Is there anything you would change about our community?
- Do people, animals or places in our community need our help?
- What could we do to help our community?

Through these activities, children will better understand the importance of community and can actively contribute to its improvement.

## ACTIVITY: WE KNOW WHO WE ARE HELPING<sup>7</sup>

**Aim:** Understand the importance of mapping the target group's needs before project implementation and develop the ability to critically reflect on situations where assistance may be provided without regard to actual needs.



**Materials:** The book "The Possum Who Didn't Laugh" by Frank Tashlin, papers and stationery. Access YouTube for an alternative to the book (<https://www.youtube.com/watch?v=oFGabU7iKKE>)

### Procedure for the teacher:

Introductory discussion: Ask the pupils to think about situations in which other people have intervened in their lives. Ask them: What makes you happy? Please encourage them to share their examples. After a few answers, ask the following questions:

- Have you ever wanted to make someone happy, but they did not like it?
- Have you ever been forced to do something you did not want to do?
- Have you ever had someone say something about you that was not true?

Working with the book: Introduce "The Possum Who Did not Laugh" to the pupils. Ask them if they know this book and what it might be about. Discuss why the possum did not laugh.

Read the book using the guided reading method, dividing it into four parts and discussing the plot and characters between each part:

After the first part, "What did you learn about possums? How do you think the story will unfold?"

After the second part, "What stood out to you in the story? How does the possum feel now? What is next?"

After the third part, "What happened now? What will happen to the possum and the people?"

After Part IV: Briefly summarise the story and its message.

Reflection using the RAFT method:

Invite pupils to think about the story using the RAFT method. The pupils' task is to put themselves in the shoes of one of the characters in the story or someone who knows the story and create a new text based on that role.

Assignment for RAFT:

R (Role): Who is the author of the text? (e.g. a possum, a person from the city, an animal from the forest, a journalist...)

A (Addressee): To whom is the text addressed? (e.g. city residents, conservationists, politicians...)

F (Form): What form will the text take? (e.g. a letter, a thank you note, a newspaper article, an advertisement...)

T (Topic): What is the text talking about? (choose a specific topic, e.g. helping without knowing the needs, understanding others...)

<sup>7</sup> Ambrozyová, V., Janičinová, B., Svatá, K., et al. (2019). *Metodika programu Active Citizens pro 2. stupeň základních škol. Člověk v tísni, o.p.s.*



Presentation and final discussion: let the pupils present their texts to the others. Discuss how the pupils have taken on their role and what their writing reflects about the importance of understanding the target group's needs.

Ask the final question: "What can we do to ensure we do not behave like city people when implementing the project?"

The activity is critical to understanding aid risks without communicating and understanding the target group or those affected by the problem. Pupils will realise that it is essential to thoroughly research and understand the needs of those they want to help. This process leads to better planning and implementation of projects considering and meeting people's needs.

#### **4.2. Community survey, problem selection and analysis**

Community research, problem analysis, and assessment are critical phases of project development. They help learners clearly understand the problem, focus on identifying its causes, and then look for possible solutions and available resources.

##### **Community survey**

The community survey gives students a perspective of the community, those who live there, and the project they will be tackling to tackle the community, not just for the community. During the community mapping, the children have identified the problems in the community from their perspective. However, at this stage, the children will find out how the community or partners in the community perceive these problems so that they can do a more comprehensive mapping and identification of the issues.

There are several activities you can use for community surveys. The survey needs to be prepared with the children and then evaluated. The survey phase is a precious experience for children, and before conducting the survey, it is recommended to go back and explain why it is essential to survey needs. This exploration should be followed by selecting the problem the project will address.

You may also choose a slightly different approach when selecting a problem and researching needs. After the community mapping activity, you can choose a problem the students identified in the mapping phase. You can then focus the community survey on this problem and what those affected by it think about it or how they would like to see it solved.

## ACTIVITY: PREPARATION FOR COMMUNITY SURVEY<sup>8</sup>

**Aim:** To prepare the implementation of a community survey with a stated purpose and implementation strategy.



**Materials needed:** stationery

### Procedure for the teacher:

**Introduction:** Build on the previous activity and ask how the children might find out how other people see the community and its problem areas or how they see the problem you have selected. If there is no response, they could survey residents and suggest doing it yourself.

Prepare a survey strategy. In the first step, set the objective. What exactly do you want to find out? What is the community lacking in general, or do you want to determine if the community is interested in your defined topic?

Do a brainstorming of survey questions. What precisely will you ask residents?

- Ask questions about what works and what the community is proud of (in general or within a topic).
- Ask about their ideas of what could be (for example, what a park might look like for you to go there).
- Ask questions about how to do it. Plan what will be, and look for a way to make it happen. (For example, can you think of anything that could be done to make it happen?)

Create an outline of the conversation: The interview should include:

- Outreach - introducing the pupil to the school and explaining why you are conducting the survey.
- Survey - a list of open-ended questions to ask the respondent in a logical sequence
- Conclusion—The respondent is given the floor. Can you ask them, for example, what else they would like to add? Is there anything they have forgotten?
- Thank you and end the conversation.

Arrange who you will approach so that you have enough information. Do you want to get an opinion from a particular group? Don't forget critical local figures (such as the mayor).

Agree on how you will carry out the survey. Will the survey take place in lessons or otherwise? How will you divide the tasks? When will you carry out the survey?

Prepare record sheets with the pupils for the pupils who will be carrying out the survey. The sheets should have an outline, questions, and space to record.

<sup>8</sup> Ambrozyová, V., Janičinová, B., Svatá, K., et al. (2019). *Metodika programu Active Cizizens pro 2. stupeň základních škol. Člověk v tísni, o.p.s.*



### Survey data collection

Data collection in a survey does not have to be by enquiry only. For example, you can also take a walk around the village with notebooks and cameras. Through them, children can capture places of potential interest for a service-learning project. For example, this can be a task for one group, and the other group can conduct the interviews.

When conducting interviews, it is recommended that children walk in pairs, with one asking questions and the other taking the recording. The questions should be simple and open-ended, and the children should not interrupt the respondent. These recommendations can also be discussed with the children in preparation for the survey.

### Evaluation of the survey

After conducting the survey, it is essential to evaluate the study with the pupils and reflect on their experiences in surveying the community. Pupils get emotions out of themselves during the evaluation, and at the same time, a process of conscious learning about the different contexts in the community occurs. They need to evaluate the findings they obtain and, based on this, choose the problem to be addressed in the next step in the service-learning project.

## ACTIVITY NAME: EVALUATION OF THE SURVEY<sup>9</sup>

**Aim:** To process the outputs from the community survey.

**Materials needed:** Post-it notes, flipchart paper, stationery



### Procedure for the teacher:

Survey reflection: In a free discussion, have the students share their experiences and reflections on the community survey. Ask them questions:

- How was it for you?
- What did you find?
- Did you learn something new?
- Were you able to reach all the respondents you wanted to reach?
- How did people react?

Have students write what they found in groups and support them in writing. Divide them into groups according to how they did the research. On sticky notes, have them write down the essential findings they learned from local people (topics, opinions, problems, what works, activities that would be useful in the village, etc.).

On a flipchart paper, group all the findings according to how they relate to each other into several topic areas.

Then, name the thematic categories (e.g., enough green space, good sports facilities, poor public transport accessibility, lack of separate waste containers, etc.).

Establish criteria for selecting the project topic.

Invite participants to think about what topic they would like to address. List standard criteria that indicate the topic they should consider or help them define. You may use the following as an example:

- The topic is close to the students (they understand it, they are interested in it).
- The topic appears to be an essential issue in the community.
- A socially beneficial project could be organised around the topic.
- The topic is related to global issues.
- The topic can be worked on in the long term.

Discuss each topic and then follow one of the problem selection activities.

<sup>9</sup> Ambrozyová, V., Janičinová, B., Svatá, K., et al. (2019). *Metodika programu Active Citizens pro 2. stupeň základních škol. Člověk v tísni, o.p.s.*



## Problem selection

At this point, reflecting on the issues currently affecting the community is relevant. The activity of getting to know and exploring the community may give your class some ideas for potential service-learning projects. At this stage, you need to decide with your students what the problem you will address in the project will be. If you have implemented the previous activity well, the map and the survey will set the pupils on the right path.

When mapping, children sometimes come up with ideas of what they would like to do or suggestions for specific activities, not the problem. Therefore, bringing them back to the problem, not the activity, is essential.

The following activities can still help you choose the problem your campaign will address.

## ACTIVITY: PROBLEM SELECTION (VERSION 1)<sup>10</sup>

**Aim:** The aim is to assess community problems and select a problem to address in the project. Students try to match their interests and ideas with the community's needs.



**Materials needed:** flipchart paper, stationery, sticky notes, map (from the Mapping the Community activity).

### Procedure for the teacher:

**Introduction:** Show the class the community map you and the students created in the Community Mapping activity and have one of the students summarise what you found in this project. Also, remind them that the project should benefit your community and help solve a challenge. Do a small class survey: What could your project address? On flipchart paper, write the following questions in two columns:

- What would you like to change/prove?
- What topics could benefit your community?

Hand out sticky notes and let the pupils answer the questions - one for each sticky note.

**Evaluate your class research:** Tell the children to write their answers under the questions. Invite them to glue the topics together. Look for and suggest (e.g., with a marker) a connection between what they would like to do and what the community needs (e.g., they are interested in environmental issues and would like to be involved in restoring a park in the community). Name key themes that link the student's interests and the community's needs. Try to select an issue with the pupils that they would like to address in the project in a collaborative discussion.

<sup>10</sup> Ambrozyová, V., Janičinová, B., Svatá, K., et al. (2019). *Metodika programu Active Cinizens pro 2. stupeň základních škol*. Člověk v tísni, o.p.s.

## ACTIVITY: PROBLEM SELECTION (VERSION 2)<sup>11</sup>

**Aim:** To identify current issues in the community that the class can and wants to address and to encourage collaboration between pupils in mapping and analysing the problems.



**Materials needed:** leaflets or pieces of paper, writing utensils

### Procedure for the teacher:

**Identifying problems:** Ask each student to write on paper the issues you identified in the community mapping activity and the survey.

**Group discussion:** Divide the pupils into groups of up to five. In each group, have students share the problems they wrote on the slips of paper and group similar problems. Then, ask them to draft a statement that describes each problem, including details about the different contributions from group members.

**Presentation and grouping of problems:** Ask each group to choose up to three issues they think are the most important and would like to address in the project and share them with the rest of the class. After each group's presentation, group similar problems together again to create a more comprehensive and generalised list of community problems.

**Choosing a problem to solve:** From the resulting list of problems, ask the students to vote on one to be solved in the project. Once the problem has been selected, ask the groups to reflect on the following questions:

- Is this problem present everywhere in the neighbourhood or only in certain areas?
- Does this problem only affect a particular group of people?
- How can we find out more about this issue?
- Is this a challenge that we can overcome? What or who can help us as a partner?
- How can we better define the problem and start to solve it?
- Is there anyone already dealing with this issue?

<sup>11</sup> Sosa Rolón, A. J. (2020). [Resource book for the development of service-learning projects](#). CLAYSS.

## ACTIVITY: PROBLEM SELECTION (VERSION 3)<sup>12</sup>

**Aim:** To help the class select the best ideas from a range of options through democratic voting, encouraging the involvement of all participants in the decision-making process.



**Materials needed:** stickers (each participant needs three stickers), sheets of paper, writing utensils (pens, markers), a room with enough space to spread out the sheets of paper

### Procedure for the teacher:

**Introduction:** go back to the community map or the survey result and list the problems you have identified with the students. Write each project on a separate sheet of paper. If some are very similar, consider combining them into one.

Spread individual sheets of problem paper around the room. Make sure that the sheets are visible and accessible to all pupils.

Give each participant three stickers. Explain that they will use these stickers to vote for the ideas they like best. Instruct the students to stick their stickers on the sheets of paper with the ideas they prefer. They can stick all three stickers on one idea, spread them out over three different ideas, or choose any other combination.

When the voting is over, collect the sheets of paper and count the number of stickers on each sheet. This number will determine which ideas are the most popular.

If some ideas get the same number of votes, give the participants another sticker and have them vote again, but this time only among these same options until you get a clear winner.

The winning problem area with the most stickers becomes the basis for further work or project implementation.

**Conclusion:** discuss the winning problem with the class.

<sup>12</sup> Roots and Shoots. (2017). [Roots and Shoots Toolkit](#).



## Problem analysis

Problem analysis is used to help children understand the complexity of the challenge they are going to solve and the connection between the causes of the problem and its consequences. To analyse an issue, use the problem tree technique. You can then work effectively with the problem tree in the next stage of setting project goals.

## ACTIVITY NAME: PROBLEM TREE

**Aim:** to identify the causes and consequences of the problem the pupils have chosen to solve and to consider possible solutions.



**Materials needed:** A3, markers

### Procedure for the teacher:

Remind yourself of the problem you have chosen to solve. Explain that you will be creating their "problem tree", an activity that will help them better understand the problem they are dealing with. Students will illustrate a tree that represents the three components of the problem:

- Problem (trunk) - What problem or challenge are we addressing?
- Causes (Roots) - Why does this problem exist?
- Implications (branches) - What are the implications of this problem?

Divide the children into smaller groups, and each group can proceed independently. Or work with the whole class. Tell the pupils the following instructions:

**Step 1:** Draw the trunk of your tree and write the problem in it—Tree trunk. Be sure to leave enough space below and above the trunk for the roots and branches of your tree.

**Step 2:** Next, you will determine the causes of the problem. The causes of the problem will represent the roots of the tree. For each cause, you draw one root from the tree trunk.

**Step 3:** The cause of the problem often has other underlying causes. For each case identified, ask "why?" to uncover any root causes. Write each root cause as another root that branches off from the original root. The more you ask "why," the deeper the roots of your tree will be deeper.

**Step 4:** Next, determine the problem's consequences, which will be represented by the branches of the tree.

For each consequence, draw one branch from the tree trunk. To find other influences, ask: "What happens then?" for each effect. Write each additional effect as a branch or leaf of the main branch. The more you ask "What happens next?", the more branches and leaves your tree will have.

**Discussion:** If students did the problem trees in groups, have them present their results and work together to create one problem tree. End the activity with a reflection:

- Does this represent reality?
- Which causes and consequences are improving, which are getting worse, and which are staying the same?
- What are the most serious consequences? Which are of greatest concern?
- Which causes are the easiest/most difficult to address? What could be possible solutions or options? Which causes could we eliminate?

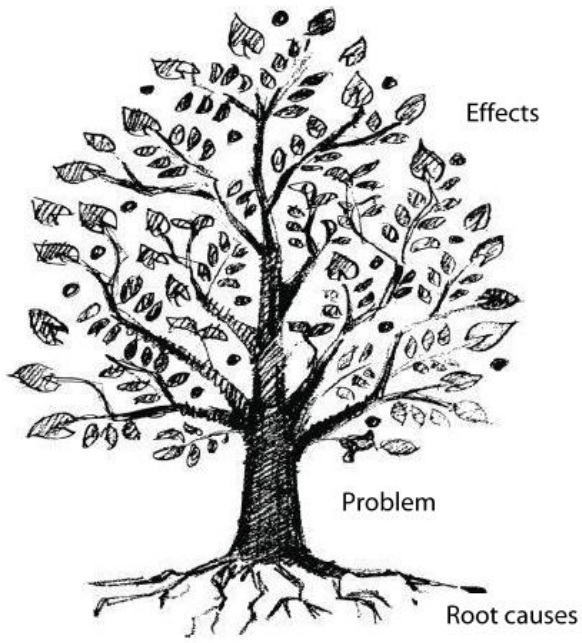

## 5. Project planning

In this step, students have already selected the problem they want to solve in the project and understand its causes and consequences. They now need to identify the goals they want to achieve with their project and plan activities to achieve them. Based on the goal, pupils decide what they will do, plan the steps and make a timetable. In the process, pupils learn project management planning methods.



### 5.1.Explanation of the project cycle

This activity builds on the previous steps of community research and topic selection. It helps students better understand how a project is carried out and the different phases of the project cycle. Pupils will also realise that their work does not have to end with the completion of one project but can start other initiatives that will continue in the future.

## ACTIVITY: INTRODUCTION OF THE PROJECT CYCLE

**Aim:** To introduce the scheme of the project cycle, explain the different phases, and prepare students for planning and implementing a service-learning project.

**Materials needed:** visualisation of the project cycle (e.g. on a whiteboard, flipchart or digitally) | Writing materials, note paper



### Procedure for the teacher:

**Introduction to the project cycle:** Start by introducing the pupils to the project cycle diagram. Explain that preparing and implementing a socially beneficial project can be considered a cycle of several phases. This cycle will help them organise the steps and understand that working on a project is gradual.

**Overview of the phases of the project cycle:**

**We will plan:**

At this stage, you set the project goal, create a timeline, divide the tasks, and prepare the project for implementation. Explain to the pupils that good planning is the basis for a successful project.

**We will implement:** This phase involves the implementation of the project and the specific activities that lead to the achievement of the goal. During implementation, it is essential to monitor the project's progress, impact and changes it brings about.

**Evaluation:** At the end of the project, it is necessary to evaluate its benefits and impact on the community. Based on this evaluation, you can identify the next topic to address or suggest improvements for future projects.

**Application for your project:**

Explain to the pupils that they are now in the planning phase. They have already researched and chosen a topic they want to explore. Now they must design and implement a project focusing on this topic and help the community.

**Conclusion:** At the end of the activity, stress the importance of a well-planned project. Please encourage students to view the project as a process that allows them to solve a specific problem and gain valuable experience for future initiatives.

## 5.2.Objectives of the service in the service-learning project

We define service goals differently than we go about defining learning goals. We have addressed the learning objectives in preparation for the implementation of the project; at this stage, we can still review and adjust them according to the problem the learners have decided to solve. A service goal essentially expresses a desired change in the community - solving a problem and fulfilling a need. Service goals depend on and are set based on the results of a needs assessment conducted with various community stakeholders. This is also why conducting an adequately structured and timed needs assessment is integral to a service-learning project. We can even call them service-learning) project goals, which means that goals are only set when the problem/challenge/need has been sufficiently explored and named. The objectives should meet the so-called SMART requirements, i.e. they should be specific, measurable, acceptable, realistic and time-bound. When defining service objectives, you usually start thinking about the activities you will implement in the project to achieve them.

We offer you three types of activities to help you set the goals of the service-learning project with your students. The first activity enables children to understand the link between the objectives and the activities. The second two activities lead them to plan the goal of their project.

Goal setting should also consider how you will know you have achieved the goals. So, in the project, you should also plan with the pupils the outcomes that will serve as evidence of success and how to evaluate them. You can plan the outcomes as part of the project objectives or as a follow-up activity.

## ACTIVITY: PLANNING OBJECTIVES FOR OUR PROJECT

**Aim:** Children will understand the importance of setting objectives. They will learn to formulate simple and concrete project objectives and realise how small steps can lead to a bigger goal.



**Materials needed:** large paper or whiteboard, coloured markers, pictures showing different activities (below), sticky notes (Post-it notes) or small pieces of paper

### Procedure for teacher:

**Introductory discussion—What is the objective?** Start with a simple question: "What do you think the word 'objective' means?" Explain to the children that an objective is something we want to achieve, for example, improving something in our school or neighbourhood. Show the children some pictures of different activities and ask them what the objectives of these activities might be.

**Activity—Planning a goal together:** Divide the children into small groups and give each group a picture of an activity. Ask them to think about what the goal of their activity could be. Each group writes its goal on a sticky note and sticks it on a large paper or whiteboard.

**Discussion - Are our goals concrete?:** Go through all the written objectives together. Discuss with the children whether their goals are specific and how they can improve them. Explain to the children that it is essential that the goal is clear and that they know how to achieve it. For example, if the goal is "Our playground will be prettier," they can refine it to "We will plant 10 flowers around the playground to make it more colourful."

**Final activity—Steps to the goal: Now that they have set their goals, ask each group to think about what they would need to do to reach them.** For example, if their goal is to plant flowers, what steps would they need to take (e.g., "Buy flowers," "Prepare soil," "Water flowers")? Each group writes these steps on small pieces of paper and sticks them under their goal on a large paper or board.

### Discussion - The road to the goal:

Together, go through the steps written by each group. Explain to the children that reaching a goal is like walking along a path where each stop (step) moves us closer to the goal. Review why goals are important and how the steps help us reach them.

### Examples of objectives and activities:

**Goal:** "Our school will be cleaner and nicer."

#### Activities:

- We will organise a weekly cleaning of the schoolyard.
- Plant flowers and plants in the school garden.
- We will make and deploy waste sorting bins.

**Goal:** "We will reduce the amount of plastic waste at school."

#### Activities:



- We will organise a fundraiser to buy eco-friendly lunchboxes and water bottles for the students.
- We will give a lecture on the importance of recycling plastics and reducing waste.
- We will organise a competition for the best ideas to reduce plastic waste in school.

**Goal:** "Make our school playground safer for all students."

**Activities:**

- Together we will repair and inspect the sports equipment on the playground.
- We will create information boards with rules for safe behaviour on the playground.
- We will organise an event to paint safety lines and symbols on the playground.

**Goal:** "We will promote healthy lifestyles among our classmates."

**Activities:**

- We will organise a healthy eating week at school, where we will prepare healthy snacks every day.
- We will prepare and lead exercise classes in the schoolyard.
- We will make posters about healthy eating and exercise to be distributed around the school.

## ACTIVITY NAME: GOAL TREE (PROJECT OBJECTIVES PLANNING VERSION 1)

**Aims:** Pupils transform the problems identified in the problem tree into positive goals, creating a "goal tree" as a basis for project planning. Pupils identify key project entry points and possible solutions to the problems.



**Materials:** large sheets of paper, writing utensils, coloured crayons and markers, Problem tree created in the previous activity, Flipchart or whiteboard

### Procedure:

**Introduction:** Begin by reminding students of the problem tree they created in the previous activity. Explain that they will now turn these problems into positive goals that will be the basis for their project.

**Transforming problems into goals:** Divide students into groups and ask them to reformulate each problem in the problem tree into a desired positive outcome. For example, if the problem was "lack of green space in the village," the goal could be "increase green space in the village." **Creating a Goal Tree:** Each group places their reformulated goal where the original problem was in the problem tree. In this way, they create a "goal tree," where each goal is based on the root solutions (the original root causes of the problems) and leads to the desired outcomes (the original consequences of the problems).

**Identify key entry points:** After creating the goal tree, ask the groups to identify the key entry points for the project. These are places where they could start working towards the goals, for example "plant trees in public spaces" as an entry point for the goal "increase green spaces in the village."

**Presentation and sharing:** Each group presents its goal tree and discusses its findings. Other pupils can ask questions and offer suggestions for improving the objectives or for the project's next steps.

**Relevance of the activity for the project:** *the activity helps students to translate problems into positive goals and to identify key steps that will help them to achieve change in the community. The Goal Tree provides a visual and logical framework for project planning, ensuring that all goals are clearly defined and linked to specific actions.*

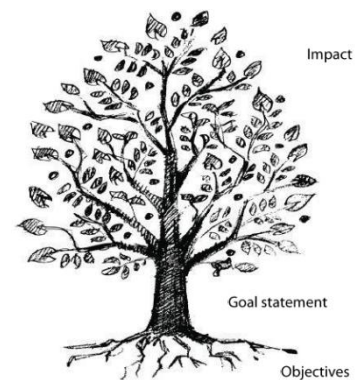

## ACTIVITY NAME: CROSSING THE BRIDGE (PROJECT OBJECTIVES PLANNING VERSION 2)<sup>13</sup>

**Aim:** Pupils will learn to link an identified problem to clearly defined objectives and realise the importance of formulating objectives that respond directly to the identified problem. Pupils plan activities that will directly contribute to achieving the identified goals.



**Materials needed:** large sheets of paper, writing utensils, coloured crayons and markers, flipchart or whiteboard

### Procedure for the teacher:

**Introduction:** Introduce the concept of "crossing the bridge". Explain that this helps to link the problem to the objectives and activities of the project. The bridge symbolises the transition from the current problem to the desired outcome (goal) through the planned activities.

**Problem and goal identification:** Each group will take one of the problems they have identified in the previous activities. They will write the problem in the left rectangle on their diagram. Ensure the problem is phrased as a negative statement, for example, "lack of green space in parks" or "high levels of litter in public spaces". Groups then reformulate the problem into a positive goal and write it in the right rectangle. For example, 'increase the amount of green in parks' or 'reduce litter in public spaces'.

**Consistency test:** After filling in the problem and goal boxes, students check whether the goal corresponds precisely to the identified problem. If not, the objective or the problem must be reworded to make them consistent. For example, if the problem is "lack of safe bike lanes," the goal should be "create new safe bike lanes."

**Planning activities:** In the central arc (bridge) of the diagram, write the planned activities that should lead to achieving the goal. Invite students to think about specific steps to move from the problem to the goal, such as 'organising volunteer tree planting days' or 'campaigns to promote waste sorting'.

**Testing the effectiveness of the activities:** After writing the activities, the groups reflect on how they will contribute to achieving the goal. Each group member should be able to explain how a particular activity will help solve a problem. If the activities are not clearly linked to the goal, the group should review and revise them to make them more problem-solving-oriented.

**Presentation and sharing:** Each group will present its "crossing the bridge" to the others. Together, check that the objectives, problems, and activities are in line and that the planned activities actually lead to the desired goal. Discuss whether the activities could be improved or changed to be more effective.

**Relevance of the activity to the project:** *This activity helps learners think carefully about how their goals and actions are linked to the identified problem. It teaches them that in order to achieve the desired results, they need clearly defined goals and planned activities that are directly related to*

<sup>13</sup> Sosa Rolón, A. J. (2020). [Resource book for the development of service-learning projects](#). CLAYSS.



these goals. This process reduces the risk of project failure and ensures that all activities contribute to solving the problem.

**"Crossing the bridge" scheme:**

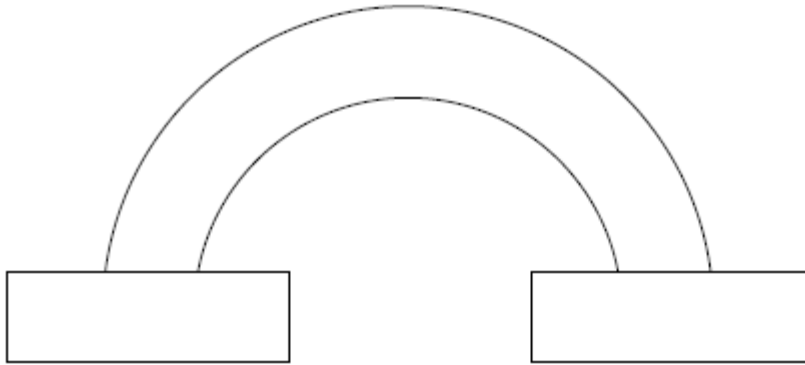

## ACTIVITY: MEASURING PROJECT SUCCESS

**Aim:** Children will learn to identify specific outcomes that indicate they have achieved the aims of their service-learning project and develop measurable criteria to evaluate its success.

**Materials needed:** large sheets of paper or flipcharts, Coloured markers, Writing utensils, Sticky notes, Examples of project outputs (prepared by the teacher)



### Procedure for the teacher:

**Introduction:** Explain to the pupils that each project has its objectives to be achieved. They need to identify their work's specific outputs or outcomes to see if they have achieved their goal. Please show examples of outputs from other projects so that pupils better understand what is expected of them.

**Discuss the outcomes:** Ask students to consider specific changes or outcomes they would like to see if their project is successful. You can use questions such as: "What should we see or experience if we achieve our goal?" or "How can we prove that our project was successful?"

**Brainstorm outcomes:** Divide students into groups and have them brainstorm ideas for possible outcomes for their project. They write each idea on a separate sticky note. Encourage pupils to think of different outcomes, such as changes in behaviour, new knowledge, improved environment, or positive feedback from the community.

**Create measurable criteria:** Have each group select the 2-3 most important outcomes from their brainstorming. Then, ask them to think about how they could measure these outcomes. What specific criteria or indicators can they use? (e.g., number of people who attended an event, percentage of improvement in a particular area, number of feedback surveys completed.) Have them write these criteria on paper and explain them to the class.

**Discussion and finalisation:** Each group presents its outputs and measurable criteria to the others. The other pupils can ask questions or suggest improvements. Together, as a class, select the best ideas and add them to the overall project plan.

**Conclusion and reflection:** Discuss with students how these outcomes and criteria will help them evaluate the success of their project. Please encourage them to refer to these criteria regularly throughout the project to evaluate their progress. Ensure they understand that measuring success is important for improving their future projects and personal growth.



### 5.3.How to combine learning objectives and service objectives

You will link the learning and service objectives through specific activities that the pupils will carry out during the project. Since service-learning connects education with service, you need to link the service and learning goals. This happens in the project planning with the children because mapping needs and planning the project is also a process in which the children learn, but also in the action itself. So, the learning process happens in service-learning through different activities.

As the teacher, you connect the learning and service goals, but the children need to be aware that they are connected so that they are aware of the learning process. The curriculum integration map or chart of learning goals and service goals are activities that you do as a teacher; we also offer activities that you can do with children.



**Worksheet for teachers**  
**Planning 1: Map of curriculum integration**

The potential of service-learning projects increases if they involve more than one curriculum area. The interaction between service and the content of multiple courses can be illustrated in the diagram below. The central rectangle in the conceptual grid will contain the general goal of the service-learning portion of the project, and the surrounding circles will represent specific learning goals. The blank spaces below each circle should be filled in with the curricular content that will be used to achieve that goal. You may indicate the appropriate subject in parentheses.

Sample diagram:

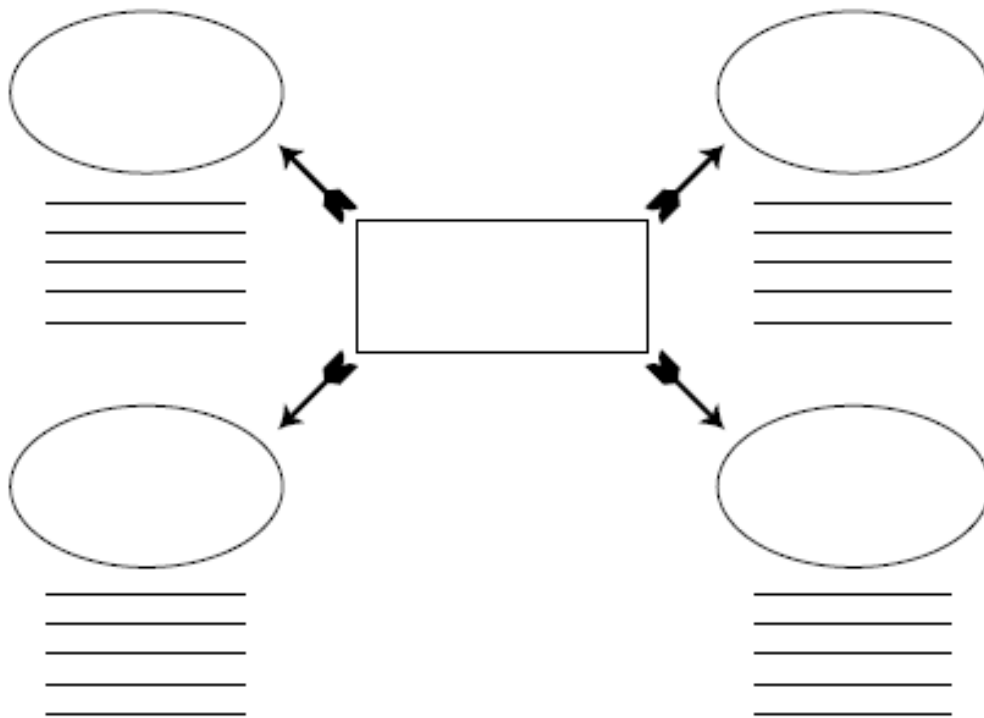



## Worksheet for teachers

### Planning 2: Table of learning objectives and service objectives

You can set learning and service objectives and try to create a table outlining how these objectives relate to each other.

We offer you an example of such a table for individual projects. However, your project may also have multiple learning objectives, then add additional activities to achieve the service objective and the learning objective

Project title	Educational objective	Performance standard	Objective of the service	Activities to achieve the objective
<b>We clean our park</b>	Pupils will learn about ecosystems and environmental protection.	The learner can explain the importance of ecosystems and describe how we can contribute to their conservation.	Improve the local park's cleanliness and aesthetics and increase community conservation awareness.	Organising a clean-up event in the park and creating educational posters about waste separation.
<b>Caring for the school bed</b>	Pupils will learn about growing plants and the plant cycle.	The learner can practically apply knowledge about plant cultivation, e.g. planting and caring for plants.	To improve the school grounds and increase the availability of fresh vegetables for the school canteen.	Establishing and caring for a school garden bed, harvesting the produce and using it in the school canteen.
<b>Writing books for children in hospital</b>	Pupils will learn to write simple stories and improve their reading skills.	The pupil can create a short story with a simple plot and correct grammatical and stylistic expression.	To improve the psychological well-being of children in hospital by providing them with new books with positive content.	Writing and illustrating stories, printing and donating books to children in the hospital.
<b>Production of birdhouses</b>	Pupils will learn the basics of working with wood and understand the importance of bird conservation.	The learner can safely use basic woodworking tools and explain the importance of bird conservation.	Increase the number of nesting sites for birds in the community and contribute to the ecosystem's biodiversity.	Production and placement of birdhouses in the school grounds or local park.
<b>Visits and help in a retirement home</b>	Pupils will improve their communication skills and develop a sense of social responsibility.	The pupil can converse with the elderly, show empathy and interest in their life stories.	Improve the emotional and social well-being of seniors in a nursing home.	Regular visits to the nursing home, reading books, conversations and joint activities with seniors.



## ACTIVITY: LINKING EDUCATION AND SERVICE GOALS WITH CHILDREN

**Aim:** Children will realise how they can use their new knowledge and skills to help the community and prepare to implement a service-learning project by planning the connection between what they learn and how they apply it in service.



### Procedure for the teacher:

**Introductory discussion:** Go back to what you have been talking about service-learning and ask if the children remember what the word means.

Remind them they have something new to learn through the project they are planning. For this activity, it is good if the children already have an idea not only of the project's aim but also of the activities they will do.

Divide the children into groups. Remind them or write on the board what the project goal is for which activity or activities in the project they have chosen. Give the children in the group questions to think about:

- What can we use from our knowledge to implement this project?
- What do we need to learn to make this idea a reality?

Each group will prepare a simple plan on paper outlining what they will learn and how they will put it into practice. They can use drawings and simple diagrams.

**Presentation and discussion:** Each group briefly presents its plan to the other children. You can give feedback and suggest further improvements to the other children.

Summarise the importance of how learning can be translated into actual actions that positively impact the community. Children will become clear about connecting their learning goals to service-learning goals and be prepared to implement a service-learning project.

#### 5.4. How do we involve the community?

When planning service-learning projects, the defined needs and outcomes of the activities are targeted to someone in your local community. This could be children with special needs, the elderly, abandoned animals, the homeless... but also your community as a whole. Usually, different organisations or institutions in the community provide different services/activities to different people, so doing the project in partnership with these organisations is a good idea. There is much to be learned from the organisations working with the people you have identified as beneficiaries of your project, the organisations providing technical support and resources, and, of course, from the beneficiaries themselves. It is always better to work with the beneficiaries rather than for them, so try to involve the people you want to support, considering their capacities, in the whole process.

If you are unsure how to find the right community partner, there are several ways to do it.

- Google it - this is the first thing we do when looking for anything and can also help us when looking for potential partners; try a Google search or searching the registries of various associations;
- Contact your local volunteer/community centre. They know the community's needs, have all the relevant information, and are part of a wider network of community organisations.
- Contact your local youth organisation or information centre. These organisations also have many contacts in the local community and provide a variety of services for young people that can enrich your learning process.

Communication with community partners is essential. Here are some tips:

- **Planning:** Involve your community partner as soon as you have your ideas clear. Check that you have properly assessed needs or need to add something you had not noticed before and that the outcomes and proposed activities are feasible. Be sure to involve the beneficiaries in this phase. Incorporating your project into their work requires planning, and before you can find a workable solution, you will probably have to make some compromises.
- **Implementation:** Inform and communicate regularly with your community partner about the progress of your project. If you encounter new challenges, inform them of the problems you are trying to solve and the solutions you are proposing.
- **Closure:** Ensure that you inform your partner about what you have achieved, i.e., the results of your project. Involve your partner's representatives and beneficiaries in the closing activities and celebration and allow them to evaluate their experience.

The 'Who are the other players?' activity can help you involve different actors in the project, as can the community map that you created with the pupils at the beginning.

## ACTIVITY: WHO ARE THE OTHER PLAYERS?<sup>14</sup>

**Aim:** Pupils map who can influence the project's implementation, analyse the level of influence of each player or group on the project and identify potential partners based on the analysis.



### Procedure for the teacher.

Remind the pupils of the mapping and what different groups or organisations are in the area where you will carry out the project. Think with the children about examples of 'players\*.

That is, those who may have something in common with the topic of your project - in any position/role. A player can be a particular person or group of people.

Divide the students into smaller groups and have them list all the relevant players. Have them invite them to write each player on a separate sticky note while thinking about what that player would say about their project.

Explain the player analysis scheme. The diagram in the next step will help you to assess the level of influence of each player and their level of support.

### Player analysis scheme

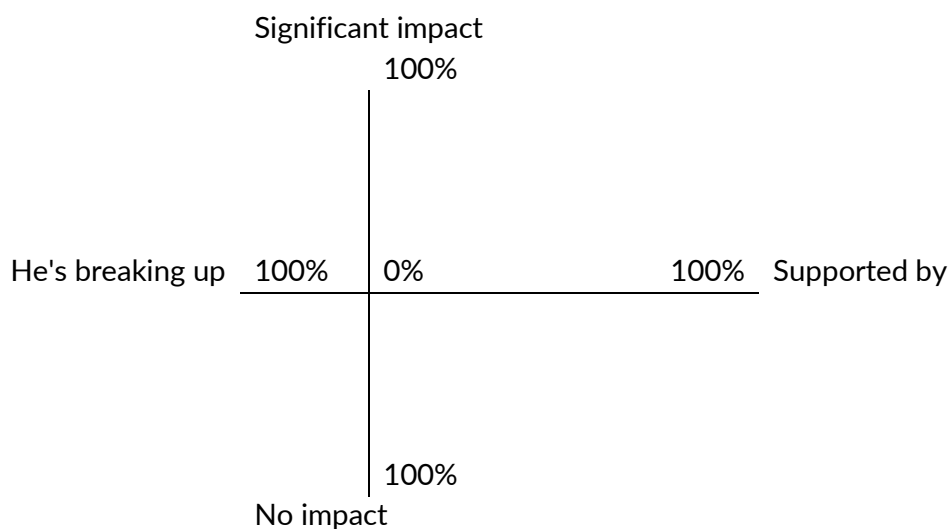

Imagine one player and evaluate what impact he would have on your project and what attitude he would be likely to take towards it. Invite students to place the player in the diagram according to the level of support for your project and the strength of that player's influence. The other players can give their opinion on whether they agree with the placement of the ticket. Ask questions:

<sup>14</sup> Ambrozyová, V., Janičinová, B., Svatá, K., et al. (2019). *Metodika programu Active Cizizens pro 2. stupeň základních škol. Člověk v tísni, o.p.s.*



- How much would this person/group support you? Or would they not support your project?
- How much influence does it have?

Invite another group to introduce another player and repeat the process. Finally, make sure that none of the key groups (e.g. local councillors or target groups - consumers, families, seniors, etc.) are missing from the list.

Ask the following questions:

- What does the analysis show? Which quadrants are most important to us - what should we focus on?
- Who specifically could we work with to make this make sense? How do we establish cooperation?
- Do we need some actors to be more supportive of our thinking? What can we do to do this?
- How can we further work with the positive attitude of a particular player towards the project? How to use it?

Write down the results. They will be helpful in planning the project schedule. You can also divide up some tasks and start reaching out to some players.



### 5.5.Planning activities to achieve objectives

You need to plan different activities within your service-learning project to solve a problem or meet a local community's needs. Activities are a method to achieve the goals of the service-learning project. When considering which activities are most appropriate for your service-learning project, you need to consider the amount of time you have available to carry them out, the number of team members and their skills and competences, and the other resources needed to carry out the project. Ensure that the activities you plan to implement contribute to the project's stated objectives, i.e., that they impact solving a problem or meeting a need.

Each activity you come up with has sub-activities that should be logically ordered. For example, suppose one of your activities is a workshop. In that case, you should create an application form, arrange the related application process, invite potential participants, find the premises where the workshop will take place, purchase materials and/or refreshments, and then implement the workshop. You can spread the word about the workshop to the media or other community members, so post on social media after the seminar. The same goes for the main activities; think about which needs to come first.

There are usually many things to do and ensure for each activity, so you and your team should define the individual tasks, who will be responsible for them, and WHEN the activity will occur. When you do this, you and your team will be well prepared to implement the service-learning project and adapt to the changes and challenges you will surely encounter.

Service-learning projects often entail certain costs, e.g. materials for a workshop, travel costs, perhaps bringing in an expert to deliver part of the activity, buying part of the equipment, or renting space to host the event. It is vital to plan these expenses so that you have everything covered and possibly enough time to raise money from other sources if the planned initial ones are not enough. By searching online or contacting providers directly, you can find out the cost of most things you need to buy, borrow/rent. Keeping track of your spending is also important; a simple tool at the end of this guide can help you budget and monitor how much you spend.

Use the following activities to plan.

## ACTIVITY NAME: STEPS TO THE PROJECT

**Aim:** Pupils will realise that each activity needs to be broken down into individual steps and design the steps and stages of their project.

**Materials needed:** Pictures of a teapot, a stove, matches, a box of tea, sugar, a mug, a skewer (you can use props instead of pictures), post-it notes, writing utensils



### Procedure for the teacher:

Invite pupils to prepare an imaginary cup of tea. Divide the pupils into teams of five. Using pictures or props, introduce the initial situation of the situation and the preparation instructions:

- You are standing in front of a gas stove, a teapot is placed on one of the burners. On the kitchen counter all the ingredients are laid out (a sealed box of tea in a bag, sugar), then a mug, a saucer, a skewer and matches. No other things are available.
- Your task is to create the most detailed instructions for making tea. Write each step on separate pieces of paper, which you will sequence in order. The winner is the person who manages to brew the tea with the most extended list of steps in the correct order.
- You have 5 minutes to complete it.

When the time is up, have the groups count the number of steps they have written down. Announce a winner, who will then read out the procedure. Check the logical order of the steps. Find out what it takes to prepare breakfast. They already have tea. Ask them what else they need to have ready to have a good breakfast. (E.g. a roll with butter, cut-up fruit, table set, a glass of juice...).

Look for a link with the pupils between the preparation of breakfast (and a cup of tea) and their project.

Ask:

- How do you think this activity relates to the preparation of the project?
- How can you use this connection in your project preparation? What happens when the description is too detailed or too general?

Explain the path to the project goal using a picture of a mountain. Explain that the goal, like the peak, cannot be reached in one go. Outline the steps to get to the peak.

## ACTIVITY: ACTIVITY PLANNING AND TIMELINE FOR A SERVICE-LEARNING PROJECT

**Aims:** Students will plan all the necessary activities for implementing their project and determine the timetable for each activity and the whole project.

**Materials needed:** large sheets of paper or flipcharts, Coloured markers, Writing utensils, a Whiteboard or projector to display the timetable



### Procedure for teacher:

**Introduction:** Explain that today's activity aims to plan all the necessary steps to carry out their project and to create a timetable. Show them an example of a simple timetable on the board or a projector.

**Write down all the activities needed:** Invite the pupils to write down in their groups all the activities needed to carry out their project. Encourage them not to forget anything and to concentrate on small details such as buying materials, preparing posters, communicating with the community, etc. When the time is up, have each group present a list of their activities and go through them together.

**Set a start and end date for the project:** Ask the pupils to work in groups to set an exact start and end date for their project. Discuss with them how much time they need to complete each step.

**Create a schedule:** Divide the activities into periods (e.g. weekly or monthly) and enter them in the schedule table. At the end of this step, each group should have a clearly defined timetable in which the activities are ordered according to their logical sequence and time requirements. Display these timetables on the board for all to see and compare.

**Conclusion and Discussion:** At the end, each group presents their timeline and solutions to possible obstacles. Together, reflect on how these plans can be even more effective and what needs improvement.

**Activity planning and timeline**

Write down all the activities needed to implement your service-learning project.

.....

.....

.....

.....

.....

.....

.....

.....

.....

.....

Determine the beginning and the end of your service-learning project.

.....

.....

.....

Determine precisely how much time you will need for each sub-activity. Organise these activities in a timetable.

Activity	Time (week/months)									

## ACTIVITY: ASSIGNING RESPONSIBILITIES IN THE TEAM

**Aims:** Pupils will divide roles within a team based on the strengths and preferences of the members; the activity promotes responsibility and cooperation between team members.

**Materials needed:** large sheets of paper or flipcharts, coloured markers, writing utensils, prepared list of possible tasks



### Procedure for the teacher:

**Introduction to the activity:** Explain to the pupils that any successful project or campaign requires team members to divide their tasks. Each team member will be responsible for completing specific tasks essential to the project's success. Give examples of the different tasks that could be part of a campaign, such as communication, organisation, materials development, logistics, etc.

**Task identification:** Have groups list all the tasks needed to carry out their campaign. Each group can use the prepared list of tasks as inspiration and add to it according to the specific needs of their campaign.

**Discuss with pupils** how much time each task requires. Help them to understand that some tasks may be more time-consuming and require more attention, while others may be less demanding but just as important.

**Division of tasks in the team:** Ask students to volunteer for the tasks they are most comfortable with. If no one can decide, suggest that team members nominate others for tasks according to where they see their strengths. Encourage pupils to choose tasks that interest them or may give them new experiences.

**Documentation of task assignments:** Each group should jointly write a list of tasks and assigned responsibilities with each team member's name. This list can be posted in the classroom or hung prominently so that all members have an overview of their responsibilities.

**Conclusion and reflection:** Ask the pupils how they feel about the division of tasks and if they have any concerns or questions. Discuss how it can be essential to communicate and help each other if someone encounters problems with their role. Please encourage them to give each other feedback and support during the campaign.

## ACTIVITY: SERVICE-LEARNING PROJECT BUDGET PLANNING

**Aims:** Pupils will plan the budget for the service-learning project.

**Materials needed:** large sheets of paper or flipcharts, coloured markers, writing utensils, prepared list of possible tasks

**Procedure for teacher:**

When planning the budget for a service-learning activity, follow these steps.

1. Write down what you need to do each activity.
2. Write down the items you need to provide by category (e.g. office supplies, refreshments, travel expenses, etc.) and quantify their financial value, i.e. the amount of money needed to purchase them.
3. Decide which items you can provide and which you will need coverage from other sources.
4. Search for the sources of the income.





## ACTIVITY: PLANNING THE PROMOTION OF A SERVICE-LEARNING PROJECT

**Aims:** Pupils will learn to plan and implement an effective promotion of their project. In this activity, students will work in three teams: graphics, media, and distribution. Each team will focus on a different part of the promotion of the project, and together, they will ensure that the project receives sufficient public attention and support.



**Materials needed:** large sheets of paper or flipcharts, coloured markers, writing utensils, computers or tablets with internet access (for the media team), graphic materials (paints, drawings, graphic software), access to a printer and photocopier (for the distribution team)

### Procedure for teacher:

**Introduction:** Explain to the students the importance of promotion in completing their service-learning project successfully. Introduce the three main areas of promotion they will focus on: graphic design, media communication, and material distribution.

**Divide the students into three teams:** a graphics team, a media team, and a distribution team. The number of pupils in each team can be balanced as needed. Ensure each team has the necessary tools and access to the resources it needs.

### Instructions for individual teams:

#### Graphics team:

Responsibilities:

- Create visual materials such as posters, flyers, and banners to promote the project.
- Prepare graphic designs that attract attention and effectively communicate the project's message.

Directions:

- Brainstorm on ideas for visual elements.
- Decide on the colours, images, and slogans to be used.
- Create final designs and present them to the other teams for approval.

#### Media team:

Responsibilities:

- Manage communications with the media, including social media, school websites and local newspapers.
- Create content for social media such as posts, videos and articles.
- Contact local media and schools to promote the project.

Directions:

- Identify the platforms on which the project will be promoted.
- Develop a plan for publishing papers and articles.
- Prepare a press release or short article for the school website or newspaper.

#### Distribution team:

Responsibilities:

- Ensure that all promotional materials reach the target audience.



- Organise the distribution of posters and leaflets to places where as many people as possible will notice them.
- Coordinate the dissemination of information among classmates, families, and the community.

Directions:

- Create a list of places where the materials will be distributed (schools, public spaces, online platforms).
- Establish a timeline for distribution and ensure that materials are deployed as planned.
- Agree on how they will measure the success of the distribution (e.g. number of leaflets distributed, community feedback).

**Working in teams:** Each team works on its tasks as instructed. The teacher is available for consultation and help solving problems.

**Presentation and coordination:** Teams present their outputs to others and discuss how their work fits into the overall promotion plan. Together, they agree on the final steps needed to implement the promotion successfully.

**Conclusion and reflection:** Discuss with the class what they did well, what challenges they had to overcome and what they might do differently next time. Encourage the pupils to monitor the effectiveness of the promotion during the project and adjust it as necessary.

## CHECKLIST FOR PLANNING A SERVICE-LEARNING PROJECT

- ✓ Did we get the community needs right?
- ✓ Is it essential for the community?
- ✓ Have we involved the community in assessing their needs?
- ✓ Have we defined the service objectives?
- ✓ Are the goals of the service related to the need?
- ✓ Have we set learning objectives?
- ✓ Are learning and service objectives related?
- ✓ Are the planned activities related to the objectives?
- ✓ Have we divided responsibilities and roles in the team?
- ✓ Have we made a timetable?
- ✓ Do we have a budget for each activity?
- ✓ Do we have the resources to implement the project?
- ✓ Do we have a plan for monitoring and evaluation of the project?
- ✓ Do we have a plan to promote the project?

## 6. Action

This step of service-learning is about implementing a service-learning plan. This phase is critical when the learners put the knowledge into practice and actively serve the community. Its form, therefore, depends mainly on the previous step, i.e. needs mapping and planning, and on the length of time you have chosen to implement the whole service-learning project in your classroom. At the same time, reflection and monitoring are closely linked to this phase, which is also dealt with in separate sections. Here, we also give some valuable tips.



The role of the teacher at this stage could be divided into three interconnected areas.

### The role of the teacher in the action phase of service learning

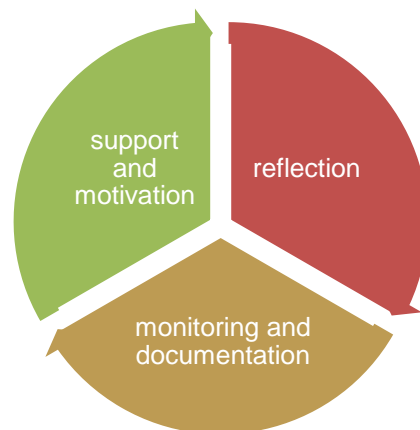

#### Support and motivation

Your role is to support and motivate the pupils during their planned service learning activities, guide them, and provide feedback. You should also be available to answer questions and solve problems that may arise. Regular instruction, encouragement, and guidance can help learners overcome uncertainty, anxiety, and nervousness.

Encourage effective communication and collaboration within the team. Encourage pupils to work together and share responsibilities. Teamwork is an essential aspect of service learning.

Help pupils to manage changes during the service-learning project. Despite thorough preparation, things may not go as you have planned. If changes occur, it is essential to help pupils manage them effectively and creatively.

Children can lose energy and enthusiasm when service-learning projects problems or challenges take longer. Therefore, it is vital to encourage them to complete tasks and achieve goals through informal support.



### Reflection

Your task is to integrate ongoing reflection into the action phase so pupils can continuously evaluate and learn from their experiences. Reflection keeps the **focus on the learning objectives**. The activities that children do in the community are not automatically linked to the learning objectives you have planned. This connection needs to be made intentionally through reflection.

### Monitoring and documentation

Your role is also to regularly track and monitor the progress of the pupils and the project through various tools and activities. This will help ensure that the project is progressing in the right direction. Monitoring records the progress of the project and allows reflection and sharing of experiences with the community. It also informs later evaluation and promotion.

#### 6.1. Tips for activities with children in the action phase

**Here are tips for specific activities with children in the action phase linked to reflection and monitoring.** However, ongoing reflection is also part of the individual activities that are part of the needs assessment or project planning. It is not necessary to implement all activities, choose what suits your class but also you as a teacher.

## Regular check-in meetings

You organise short, regular meetings where pupils share their progress, challenges and experiences. These meetings help to keep everyone on the same page and address any issues.

### ACTIVITY: MEETING IN A CIRCLE

**Aims:** Provide a space for pupils to regularly reflect on their progress, share experiences and foster team spirit.

**Materials needed:**

A talking object (e.g., a ball, stuffed animal, or other object pupils can pass around).



**Procedure for the teacher:**

**Introduction:** Organise a weekly meeting where pupils sit in a circle. Explain that this is a space for them to share their project experiences.

**Talking object:** Make it a rule that only the person holding the talking object speaks. The object can be a ball, stuffed animal, or other small object the pupils pass around. This helps maintain order and ensures that everyone has an opportunity to express themselves.

**Weekly questions:** Each week, ask a few questions to guide students in sharing their experiences and feelings. Questions may include:

- What have you done in the project this week?
- What challenges have you overcome this week?
- How did you feel in the group this week?
- What do you consider a success this week?

**Reflection:** Have each student express themselves while holding the talking object. If some pupils do not want to speak, they can move the object on without saying anything.

**Conclusion:** After the round of questions, you can reflect on the emerging common themes and stimulate a discussion on how the project can be further developed.

## Reflexive diaries

They encourage pupils to keep reflective journals in which they write down their thoughts, feelings, and what they have learned during the project. This promotes critical thinking and a deeper understanding of their own experiences.

### ACTIVITY: MY WEEKLY THOUGHTS

**Aims:** Encourage regular reflection and self-expression by pupils through writing or drawing in a weekly journal.

**Materials needed:** Journal sheets with questions, writing utensils, crayons or markers, or emoticons to cut out and stick on.



#### Procedure for the teacher:

**Introduction:** Create a simple worksheet with questions for the students to complete each week. These questions will help them reflect on their experiences and feelings about the project. An example can also be found in the children's workbook.

**Questions:** Prepare three to four questions for each week, for example:

- What did I like this week?
- What was complicated for me this week?
- How did I help in the project this week?
- What did I learn this week?

**Reflection:** Encourage pupils to answer the questions by drawing, writing short sentences, or using emoticons that they can cut and paste. Make sure they have enough time and space to express themselves.

**Journal Time:** Set aside 10-15 minutes weekly to complete your journal. This will help pupils to reflect regularly on their experiences and develop the ability to self-reflect.

**Sharing:** if students want to, they can share their journal ideas with the class or the teacher to promote mutual learning and a better understanding of their experiences.

## Reflective group discussions

You can have discussions with the children where they can talk about how they are doing in the project, what they have learned and how they perceive their impact on the community. Such formal or informal discussions help with teamwork and self-reflection.

### ACTIVITY: REFLECTIVE GROUP DISCUSSIONS

**Aim:** To foster teamwork, communication skills and the ability to reflect on project experiences.

**Materials needed:** paper and pencils for writing down ideas (optional).

#### Procedure for the teacher:

**Introduction:** Divide the pupils into small groups of three to four. Explain that they will discuss their experiences with the project and suggest ideas for improvement.

**Group discussion:** Give students 10-15 minutes to discuss in their groups. They can discuss topics such as:

- What do you like about the project?
- What could we improve in the project?

Please encourage students to write down the critical points of their discussion on paper.

**Presentation of ideas:** After time has elapsed, have each group summarise their ideas in front of the class. Each group can select a speaker to present their conclusions.

**Discussion:** At the end, you can lead a short discussion on the ideas presented, encouraging the whole class to respond to the suggestions of the other groups.



### Monitoring through presentations

During the project, you can monitor its progress through simple presentations in which the pupils present what they have achieved and receive feedback. This process helps to improve the project and keeps pupils motivated.

## ACTIVITY: PRESENTING MY CONTRIBUTION TO THE PROJECT

**Aim:** To strengthen confidence, communication skills and the ability to reflect on your contribution to the project.

**Materials needed:** drawings, models or other visual aids for pupils to use in their presentation.



### Procedure for the teacher:

**Introduction:** Explain to the pupils that each week, they will have the opportunity to present to the class what they have already achieved in the project. The presentation should be short and may include a demonstration of their work, such as a drawing, a model, or a simple explanation of their contribution.

**Preparation:** Give students time to prepare their presentation. Encourage them to think about what they want to show others and how they will explain it.

**Presentation:** Each pupil prepares and presents their part of the project in front of the class on the appointed day. For example, younger pupils can show their drawings or models and explain their work on the project. After the presentation, encourage other pupils to ask questions or give their opinions about what their classmates have shown. This step helps develop critical thinking and the ability to communicate with others.

**Reflection:** After each presentation, you can briefly evaluate what was interesting and what could be improved next time. This step boosts their self-confidence and allows them to learn from their experiences.

Support in resolving conflicts or problems

It would be best if you were prepared to help pupils resolve conflicts or problems that may arise during the project. This may include mediation between team members or helping them to overcome other challenges.

## ACTIVITY: JOINT DISCUSSION ON THE CONFLICT

**Aim:** To encourage pupils to constructively resolve conflicts, develop their ability to express their feelings, and find solutions together.



**Materials needed:** no unique materials.

### Procedure for the teacher:

**Introduction:** If there is a conflict or problem in the group, call all the pupils involved in the situation together for a meeting. Explain that the aim is to discuss the issue and find a solution for everyone.

**Discussion:** Help students express their feelings by asking them questions such as:

- How do you feel?
- What bothers you about this situation?
- What can we do to solve this?

Encourage each pupil to have the opportunity to express how they feel and for others to listen attentively without interrupting. This will help to ensure that everyone feels listened to and respected. Discuss possible solutions to the problem together. Encourage pupils to suggest solutions that are fair to all involved and to focus on positive steps they can take.

**Conclusion:** Once a solution has been reached, summarise what the group has agreed on and ensure everyone agrees on the next steps. Encourage students to remember that conflicts are natural but can be resolved calmly and respectfully.

### Ongoing adaptation of the plan

Modifying the original project plan can help pupils respond flexibly to changes or unexpected situations. This adaptation may involve reorganising tasks, changing approaches, or adjusting objectives.

## ACTIVITY: OUR NEW PLAN

**Aim:** To teach students to respond flexibly to change and to co-create new solutions when a project does not go according to the original plan.

**Materials needed:** large paper (e.g. flipchart), coloured markers or crayons.



### Procedure for the teacher:

**Introduction:** If the project is not going according to the original plan, organise a session with the pupils to review the current situation together. Explain that changes are a natural part of any project and that it is essential to be able to react to them.

**Timeline or diagram:** Draw a timeline or flowchart showing the project's different stages or steps on a large piece of paper. You can include what has already been completed and what remains to be done. Invite students to contribute their ideas for modifications to the original plan. They can discuss what could be changed to move the project forward or what new steps they could take. Have students add their ideas for a new plan directly to the paper. They can draw, write, or use coloured markers to label different plan parts. This step helps them visualise new solutions and reinforces their project ownership.

**Summary and implementation:** When you agree on the new plan, summarise the changes and how they will be implemented. Encourage learners to recognise that changes to the plan are not a failure but an opportunity to improve and continue the project.

## Teambuilding activities

During the project implementation, include various team-building activities or motivational exercises to strengthen the team and promote team cohesion, communication, and a positive atmosphere.

### ACTIVITY: BUILDING A TOWER

**Aim:** To foster teamwork and promote communication between pupils through a fun and creative task.

**Materials needed:** building blocks (e.g. LEGO, bricks), paper cups, duct tape, string, or other materials for building a tower.



#### Procedure for the teacher:

**Introduction:** Divide the pupils into small groups of three to four. Explain that their task will be to work as a team to build the tallest and most stable tower possible using the materials provided. Make sure that all group members will have to work together to achieve success.

**Rules:** Give each group an equal amount of materials and set a time limit (e.g. 15-20 minutes). Explain that the tower must be self-standing and that they can only use the materials they have been given.

**Building the tower:** During the time limit, have students work on building the tower. Please encourage them to divide the tasks among themselves and to communicate their ideas. Monitor the groups and encourage them.

**Presentation:** When time is up, have each group present their tower to the others. Pupils can explain how they worked together, what was most challenging and how they solved problems.

**Reflection:** After the presentations, discuss with the class what they did well and what they learned about teamwork. Ask questions such as:

- How did you divide the roles in the team?
- What helped you to work together?
- What would you do differently if you had another chance?

**Conclusion:** Summarise the discussion by emphasising the importance of teamwork and how pupils can use it for other tasks in school.

## 7. Reflection during and at the end of the project

The term "reflection" comes from the Latin words *reflexio* (reflection, mirroring) and *reflektere* (to reflect) and is understood as a fundamental way of learning through experience. Reflection allows pupils to think critically about their experiences and examine their values, opinions and beliefs. It also offers a space to ask questions, share ideas, experiences and problem-solving skills, and seek solutions to the community's problems for which they plan or implement their service-learning activities (Brozmanova Gregorova et al., 2020).

Reflection is an ongoing process in service-learning. It is not something that should only be present at the end of the project implementation. At the same time, reflection is not the same as evaluation. While reflection is primarily associated with the learning process, i.e. it is meant to stimulate the learning process in line with the learning objectives you set at the beginning, evaluation directs attention to assessing - either whether the learning objectives were achieved or whether the service objectives were achieved, what was done or not done well in the project, what could have been done better. Of course, reflection and evaluation are very much intertwined, especially in the project's final phase.

In the early stages of the project, you find out what the pupils' expectations, initial ideas and opinions are about what they are going to do. How and where did they form them? What ideas do they have about what they will learn, and what emotions will they experience? Reflection during the implementation of service learning takes place during your meetings with the children or through weekly evaluation activities; this also depends on the length of the project. The final reflection is looking back and finding connections between the experience and the learning outcome. This reflection also allows for looking forward, showing how the lessons learned can be used in future activities. It is thus a process that serves as a retrospective look back at the gains and losses of the previous experience and what has been achieved. At the same time, it is a process that links these experiences to future action and broader social contexts.

Several models are used for reflection in service-learning. For working with pupils in primary education, a reflection model focusing on reflection on progress, feelings (emotions), knowledge, and opportunities seems appropriate. For each focus, we offer examples of questions you can use and ask flexibly and combine with other activities with the children as appropriate.

Reflection model of progress, feelings, insights and opportunities	
Focus	Questions
STORY - naming what happened, focusing on the individual and the group	<ul style="list-style-type: none"> <li>• How do you work together?</li> <li>• What was interesting for you?</li> <li>• Did anything surprise you?</li> <li>• Which activities were the most important for you?</li> <li>• Did the activity go according to plan?</li> <li>• Were there any other unexpected situations?</li> <li>• What other course would you choose next time?</li> </ul>
FEELINGS (EMOTIONS) - we name the experienced emotions, we focus on the individual and the group	<ul style="list-style-type: none"> <li>• How did you feel during a particular activity?</li> <li>• Name three emotions.</li> <li>• When have you felt left out?</li> <li>• What were your expectations?</li> <li>• Did you meet your expectations?</li> <li>• What emotions did you experience during the activities?</li> <li>• What was the atmosphere and mood in the group?</li> <li>• Did you feel engaged as individuals?</li> </ul>
NOTES - focuses on knowledge gained through experience	<ul style="list-style-type: none"> <li>• What new things have you learned?</li> <li>• What have you learned about yourself?</li> <li>• What would you do differently?</li> <li>• How can you use the knowledge you have gained in the future or disseminate it further?</li> <li>• What have you learned from this project?</li> <li>• What did you learn? What did you learn about yourself?</li> </ul>
OPPORTUNITIES - future outlook	<ul style="list-style-type: none"> <li>• How will you continue?</li> <li>• In what ways did it take you further?</li> <li>• What can you use in life?</li> <li>• Do you see the benefit of this activity in the community targeted by the project?</li> <li>• Which of the other theories would you like to apply in practice?</li> <li>• What would you have done differently based on your learning from the activities?</li> <li>• Where would you use the knowledge?</li> </ul>

Source: Brozmanová Gregorová, Heinzová, Uhláriková, 2023

There are different ways to inspire pupils to reflect. You can discuss this with the class or individually with individual pupils. You can ask them other questions to stimulate reflection on



themselves and their learning. Various tools can be used to support reflection. Using elements of art and creativity in your work with children helps activate the brain's right hemisphere - logical thinking and concluding. Metaphorical cards, pictures, photos, music, allegorical stories, poetry or simple words referring to deeper meanings can help children to name phenomena or problems. Self-reflection often yields better results when inspired by something from the outside. Also, encouraging creativity, e.g. making collages, comics, drawings, blogs, videos or different forms of journals, gives children the opportunity to think outside the box, outside the conventional framework, and thus to notice and better understand the learning process (themselves), but also encourage motivation to reflect (Brozmanová et al., 2023).

We offer you again examples of reflective activities that you can do with children and that you can include during the project implementation or at the end of the evaluation and closure phase of the project. Modify the instruction accordingly. You will also find prepared worksheets for the children for some activities.

## ACTIVITY: FIVE FINGERS

**Aim:** To encourage personal reflection by pupils on their experiences and learning outcomes, to gain feedback and to enhance their capacity for self-reflection.



**Materials:** A4 paper, pens or crayons.

### Procedure for the teacher:

**Introduction:** Explain to the pupils that this activity aims to reflect on what they have learned and experienced during the project. Using the Five Fingers, they will reflect on their experiences and answer specific questions.

**Hand drawing:** Ask the pupils to outline their hands on a piece of paper, each finger representing one question about their experience.

**Questions for individual fingers:**

**Thumb:** What did you like the most?

**Pointer:** What didn't you like?

**Facilitator:** What is the most important thing you have learned?

**Ring finger:** Have you discovered anything new about yourself? If so, what is it?

**Little finger:** What small details appealed to you the most during the project?

**Completing the questions:** Have students write or draw their answers to the questions on each finger. They can use the words, drawings or symbols that best express their feelings and thoughts.

**Sharing and reflection:** After completing the questions, invite students to share their answers with the rest of the class. Create a discussion space where each pupil can express their thoughts and feelings and reflect on what they have learned and how it has affected their personal growth.

**Conclusion:** Summarise the discussion by emphasising the importance of self-reflection and how these experiences can help pupils further their learning and development.

## ACTIVITY: DRAWING HOW I HELPED

**Aim:** To help students reflect on how they have contributed during service learning and what they have learned about helping others.



**Materials:** paper, coloured pencils, markers or crayons.

**Procedure for the teacher:**

**Introduction:** Discuss what the students did during the service-learning project. Ask them what they remembered most and how they felt about helping others.

**Directions:** Have students draw a picture that shows how they helped during the project. This can be a specific activity (e.g., picking up trash or planting plants) or a situation that sticks in their minds. Let pupils create and encourage them to express themselves.

**Sharing:** After the drawings are finished, invite the pupils to show their work to the class and say something about what they have drawn and why they think it is essential.

## ACTIVITY: PAINTING MY FEELINGS AFTER HELPING OTHERS

**Aim:** To enable students to express their emotions about helping others during service learning.

**Materials needed:** watercolour paints, brushes, and paper.



**Procedure for the teacher:**

**Introduction:** Discuss with the pupils what feelings they may have had while helping others—joy, pride, satisfaction, and perhaps tiredness or sadness.

**Directions:** Instruct students to create a painting that shows their feelings after helping others. Please encourage them to use the colours they think best express their emotions.

**Painting:** Let pupils create and offer space to express their feelings through colours and shapes.

**Reflection:** Once the paintings are complete, discuss with the class what feelings the pupils have captured in their artwork and why they have chosen particular colours.

## ACTIVITY: COLLAGE WHAT I HAVE LEARNED

**Aim:** To encourage pupils to reflect on what they have learnt during the service-learning project and how they can express this through collage.

**Materials needed:** various magazines, newspapers, coloured paper, scissors, glue, cardboard or paper for the background of the collage.



### Procedure for the teacher:

**Introduction:** Discuss with the pupils what new things they have learned during the project—for example, the importance of cleanliness, cooperation, nature, or other topics.

**Directions:** Explain to students that they will create a collage that depicts something they learned or were most familiar with during the project.

**Selecting materials:** Allow pupils to browse the magazines and select pictures or words that inspire them and represent their experiences and learning.

**Making a collage:** Have students glue selected images and materials onto paper, adding their drawings or lettering.

**Presentation:** When the collages are finished, invite the students to show their work and explain what the different elements of the collage mean and what they have learned.

## ACTIVITY: WALL OF REFLECTION

**Aim:** To create a collective space for reflection on the service-learning experience and sharing of feelings among students.

**Materials needed:** large paper or wallpaper, markers, coloured pencils, glue, and embellishments.



### Procedure for the teacher:

**Introduction:** Explain to the pupils that they will create a common class wall that displays all their reflections and feelings from the service learning.

**Directions:** Divide the class into small groups or have students work individually. Each pupil can create a small picture and draw or write words that describe their experience and feelings.

**Creation:** Have students create their papers on paper.

**Assemble the wall:** Glue all the posts onto large paper or paper plates to create a common wall of reflection.

**Discussion:** Discuss each post and discuss what each student has expressed. Emphasise the diversity of experiences and feelings in the class.

## ACTIVITY: FEELINGS IN THE RAINBOW

**Aim:** To help students identify and visually express the different emotions they experienced during service learning.

**Materials:** paper, crayons or coloured pencils, watercolours and brushes.



**Procedure for the teacher:**

**Introduction:** Talk to the pupils about the different emotions they may have experienced during the project—joy, pride, sadness, fun, etc.

**Directions:** Tell students to draw a rainbow, with each coloured bar representing a different emotion they experienced during service learning.

**Creation:** Have students draw and colour a rainbow, each stripe symbolising a different emotion. They can add small pictures or symbols that illustrate specific feelings.

**Sharing:** After students have completed their rainbows, ask them to present their rainbow to the class and explain which colours and symbols represent which feelings.

## ACTIVITY: A PICTURE IS WORTH A THOUSAND WORDS

**Aim:** To encourage pupils' reflection on their project experience and develop their ability to express themselves metaphorically.

**Materials needed:** many pictures of different types (they can be cut out from magazines, printed from the Internet or prepared in electronic form; they can be reflective cards).



### Procedure for the teacher:

**Introduction:** Introduce an activity that uses pictures to express what the pupils have experienced during the project. Explain that they will use images to help them visualise and share their experiences.

**Image selection:** Spread the images on the table or view them on the screen (if you use the electronic version). Ask students to choose one image that best represents what they experienced during the project.

**Preparing to share:** Give students a moment to consider why they chose this particular image and what it means to them concerning the project.

**Sharing with the class:** Invite each student to show his/her chosen image and explain why he/she chose it and what it symbolises for his/her project experience.

**Discussion:** After each sharing, create a space for questions and discussion. Encourage other students to share their thoughts and reflections on the image and explanation presented.

**Conclusion:** Summarise the activity by emphasising the value of metaphorical expression and visual reflection in understanding and sharing personal experiences.

## ACTIVITY: PROJECT ON WHEELS<sup>15</sup>

**Aim:** To encourage students to think analytically, reflect on the status and direction of the project, identify necessary changes and strengthen teamwork.



**Materials needed:** large papers, coloured markers, writing utensils, possibly glue and magazine cut-outs (for collage making).

### Procedure for the teacher:

**Introduction:** Divide the class into small groups of four or five pupils. Explain that they will reflect on their project by imagining it as a car. Each group will work on creating their own "project car," which represents their project and its current state.

**Drawing and discussion:** Ask pupils to relate different aspects of their project to the different parts of the car and draw their ideas on a large piece of paper. Help them to discuss the following questions:

What is the car? Is it big, small, solid, unstable?

Which components are the wheels of the vehicle? What drives the project forward?

Which ingredients are the fuel? Does the project have sufficient energy and resources?

Where is the car going? What is the goal of the project?

Who is inside the vehicle? Who plays what role in the team? Who is the driver?

What obstacles are on the way? What can threaten the success of the project?

Are there other cars on the road? If so, what do they look like, and what do they represent?

What luggage do we take in the car? What is most important for the project?

What safety features does the car have? What is in the "first aid kit" of the project?

What stops should we make along the way? What milestones are essential?

Which things need urgent mechanical assistance? Where do they need to intervene?

**Presentation:** After 30 minutes, ask each group to present their "car" to the others. Have them explain how their drawing reflects the status and needs of their project.

**Co-creation:** In the end, you can combine the individual contributions to create one standard vehicle representing the whole project. Alternatively, you can organise a "car show" where the different vehicles are presented, similar to a car dealership.

**Conclusion:** Discuss with the pupils what they have learned from this activity. Help them identify areas that need improvement and encourage them to think about how to continue the project with a new understanding of its current state.

<sup>15</sup> Sosa Rolón, A. J. (2020). [Resource book for the development of service-learning projects](#). CLAYSS.

## ACTIVITY: DRAWING IN MEMORY<sup>16</sup>

**Aim:** To encourage the development of self-expression in pupils, to allow them to share their favourite moments from the project and to provide a space for reflecting on personal experiences.



**Materials:** paper, coloured crayons or markers, photos from the project, and writing materials.

### Procedure for the teacher:

**Introduction:** Explain that students can reflect on their favourite moment from the project and express it through a drawing or photo selection. This activity will allow them to share their personal experiences and thoughts with others.

**Drawing or selecting a photo:** Ask students to recall the moment they liked best during the project. Then invite them to draw that moment on paper or, if they have a photo, to choose one and match it to that moment.

**Written explanation:** After completing the drawing or selecting the photo, ask the pupils to write a short explanation about why they chose this particular moment and what it means to them.

**Sharing and exhibition:** Create a space where pupils can share their drawings or photographs with the class and explain why they have chosen this particular moment. Then, display their work and written explanations at the final event or on a classroom bulletin board.

**Discussion:** After the work has been displayed, you can discuss with the class what moments were the most important for the pupils and what appealed to them the most about the project.

<sup>16</sup> Sosa Rolón, A. J. (2020). [Resource book for the development of service-learning projects](#). CLAYSS.

## ACTIVITY: WHAT I BROUGHT, WHAT I TOOK AWAY<sup>17</sup>

**Aim:** To encourage reflection on personal development during the project and evaluate what the pupils have gained and brought with them initially.



**Materials needed:** large paper or poster, writing utensils, or a computer or tablet to create a word cloud.

### Procedure for the teacher:

**Introduction:** Sit the pupils in a circle and explain that this activity aims to help them reflect on what each of them brought back at the beginning and what they took away at the end of the project. These reflections will help them better understand their personal development.

**Discussion Questions:**

- What did you bring at the beginning of the project? Consider what expectations, fears, knowledge or doubts the pupils had.
- What do you take away from this experience? Focus on new knowledge, changes in concerns, connections made, lessons learned, or other aspects that have changed.

**Collecting answers:** Have each student express his/her answers to the given questions. Record them on a large piece of paper or a poster, creating two sections: "I brought" and "I took away."

**Creating a word cloud:** Once the answers have been collected, create a word cloud (using online tools such as WordArt or Tagxedo) where different aspects of personal development will be visually displayed according to frequency and meaning.

**Discussion and reflection:** Present the word cloud to the students and discuss what they learned about their personal development and project from these responses. Ask them to reflect on what helped them and what they could improve.

<sup>17</sup> Sosa Rolón, A. J. (2020). [Resource book for the development of service-learning projects](#). CLAYSS.

## ACTIVITY: FROM THE TOP OF THE MOUNTAIN<sup>18</sup>

**Aim:** To encourage reflection on personal and group experiences during the project, visualise the journey towards the goals, and identify key moments and events.



**Materials needed:** sheets of paper with a mountain drawing (you can prepare in advance or let the pupils draw the basic shape of the mountain), coloured crayons or markers.

### Procedure for the teacher:

**Introduction:** Hand out sheets of paper with a mountain drawing or ask pupils to draw a large mountain with a peak and base. Explain that their task is to illustrate their journey from the beginning of the project to its goals.

The meaning of each point:

- **Currents for refreshment:** Draw moments that brought a new touch to the project and released tension.
- **Campfire gatherings:** Record the moments when there was a real connection with others and where teamwork was most evident.
- **Scenic Perspectives:** Record moments when they had the opportunity to look at the project from a larger perspective and understand its complexity.
- **Shortcuts through the forest:** Illustrate events or situations that accelerated the project's progress or moved it forward.
- **Rocky terrain:** draw moments when pupils had to cope with difficulties or obstacles.
- **GPS Activated:** Please list the situations that necessitated the change in project direction and the reasons for the change.

**Drawing:** Have the pupils illustrate on their papers all these moments and paths they have taken during the project. Please encourage them to be creative and use different colours and symbols.

**Sharing and discussion:** After completing the drawings, ask each pupil to present his/her "project output" to the others. Have them explain what each part of the mountain represents and why it is essential to them.

**Reflection:** Ask final questions to stimulate reflection:

- Have we reached the top? Have we achieved our goals?
- What pleasant and unpleasant surprises did we find along the way?
- Have we all followed the same path? How did our paths differ or coincide?
- What did we learn during this journey?

<sup>18</sup> Sosa Rolón, A. J. (2020). [Resource book for the development of service-learning projects](#). CLAYSS.

## 8. Monitoring and documentation during and at the end of project implementation

Recording the activities and achievements during the project implementation is vital for later evaluation and for the sustainability or continuation of the project. Not everything in a project is likely to be as planned, so it is a good idea to record the experience. This will allow the pupils to learn from the experience later on.

Involve pupils in documenting the whole process of project implementation (e.g. through photos, videos, blogs). This can also be one of the roles and responsibilities you define in the team. In for recording there are several possible ways and tools. We offer you some tips on how to do this with pupils in primary education.

Examples of monitoring and documentation activities

## ACTIVITY: OUR PROJECT ALBUM

**Aim:** Create a collaborative album or wall panel to visualise the project's progress, encourage teamwork, and increase pupil engagement.



**Materials needed:** a large notebook, glue, coloured paper, markers, photos, drawings, quotes, and a computer or tablet (if you create an online version).



### Procedure for the teacher:

**Introduction:** Introduce the idea of creating a project album or bulletin board to document the progress of their project. Explain that they will add new items each week to keep track of their progress.

**Choosing a format:** decide together with your pupils whether you want to create a physical album a bulletin board, or an online version using an app like Padlet. Involve pupils in deciding what the album will look like.



**Creation:** Invite students to add new items to the album/panel each week.

These can be:

- Photos from work on the project
- Drawings or illustrations showing their activities
- Short texts or reflections on what they learned or how they felt
- Quotes from their experiences that inspired them



**Sharing:** regularly view new additions to the album/panel with the whole class. Discuss what these items are teaching them about their progress and teamwork.

**End of the project:** at the end, go through the whole album or panel together. Have students share the project's meaning and how their skills and knowledge have changed. Encourage them to reflect on what was most important and what they will take away from the project for the future.

## ACTIVITY: EXPERIENCE DIARY<sup>19</sup>

**Aim:** To encourage pupils to systematically record their experiences during the project, develop communication skills, and provide tools for reflection and communication.



**Materials needed:** paper notebooks, digital tools (e.g., note-taking apps), cameras or smartphones, or recording devices.



### Procedure for the teacher:

**Introduction:** Explain to the pupils that their task will be to keep an "Experience Diary" throughout the project. This diary will help them record all the important moments, tasks, events, and personal experiences they have.



**Keeping a diary:**

**Paper or digital:** Let students record their notes using a paper notebook or digital tools.

**Entries:** Encourage students to add different types of entries to the journal, such as:

- **Tasks and events:** record what was done, when and where.
- **Anecdotes and personal feelings:** Write about your feelings, fears and experiences.
- **Images:** Add photos or drawings illustrating their project involvement.
- **"Before and after":** document how things changed during the project.
- **Recordings:** if possible, make audio or video recordings of project activities.



**Recording during the project:** have students regularly add notes to the journal, preferably after each significant activity or event. This process can be done individually or in small groups.

**Reflection and communication:** After the project, invite students to review their journals, summarise the highlights, and share their experiences with the group. Discuss what they learned, what surprised them, and how their experience changed.

**Presentation:** At the end of the project, you can create an exhibition or presentation where the pupils show their diaries, photographs, recordings and other materials. This will allow discussion and reflection on the overall project experience.

<sup>19</sup> Sosa Rolón, A. J. (2020). [Resource book for the development of service-learning projects](#). CLAYSS.

## ACTIVITY: SUMMARY OF PROJECT EXPERIENCE<sup>20</sup>

**Aim:** To help pupils systematically summarise critical aspects of the project and effectively communicate results and experiences.

**Materials needed:** paper or digital document, camera or smartphone to capture images, access to graphing tools to create charts or illustrations.



### Procedure for the teacher:

**Introduction:** Explain to the students that their task will be to create a brief project summary that includes vital information and visual elements such as photographs and images. This summary will be used to communicate the project and its results.

**Project Summary:**

**Format:** Specify that the summary should contain clear and concise information and not exceed one page (or digital equivalent).

**Content:** suggest students to include the following:

Name of school:

Name of the project:

Start Date:

Brief description of activities:

Community and partner participation:

Number of teachers:

A number of pupils:

Number of community partners:

Other participants:

Achieved results which were successful:

**Photos, charts and images:** Add visuals that illustrate key moments and achievements of the project.

**Summary creation:**

**Working groups:** Divide the pupils into small groups and let them work on creating a summary. Each group can focus on a different part of the summary.

**Visualisation:** Have students add pictures, graphs and illustrations to enrich the text and make the summary more attractive.

**Presentation and discussion:** After the summary, let each group present their output. Discuss the main findings and what they learned while creating the summary.

**Share:** Post the summary on the school bulletin board, in the school newsletter, or on the school website and social media.

<sup>20</sup> Sosa Rolón, A. J. (2020). [Resource book for the development of service-learning projects](#). CLAYSS.

## 9. Promotion and communication as part of a service-learning project

Promotion and communication are ongoing processes in service-learning. By communication, we mean keeping each other informed about the progress of the project in the team and communicating with the different stakeholders.

Promotion is the communication of the project. It allows others to become more aware of the problems in their community and possible ways to get involved in solving those problems. We will not save the whole world through one project, and we may not even find a complete solution to the need we discover. However, even by starting small and communicating what we are doing to as many people as we can reach, we can ultimately be "responsible" for a big success. **You can promote:**

- **Details of the project** - what you are doing, why you are doing it, who you are, what your objectives are, where you are and when your activity is taking place.
- **Details of the need** - what and how you have identified it in the community, why it is a problem, who are the beneficiaries, people or organisations involved or responsible for it.
- **Details of the process** - what do you do at a particular time? For example, specific things like We just started this project, we've done research, we've met with beneficiaries, we've found great partners, we're fundraising, we've had another planning meeting, we've organised our first activity, we're doing one fantastic event, we're reflecting on our experience, we've accomplished this, we've found some obstacles, we've adjusted our plans, we've achieved our goals, these are our results, etc.

Of course, these are just a series of general examples that you can adapt to the specific details of your experience and needs.

Here are a few ways we can promote your project and activities:

- Website or blog,
- Posts, lives, stories, videos, polls, challenges or any communication on your social network account,
- Publication of a newsletter,
- Posters in your school or organisation, or even in the city where you have permission and it is relevant,
- Individual emails,
- Press releases, interviews or videos,
- Presentation at other meetings or events with the relevant public.

## 10. Evaluation

Since service-learning combines learning and service, evaluation in service-learning is specific in that I need to focus on both aspects of the strategy. Evaluation of learning is tied to learning objectives, service evaluation is tied to the achievement of service goals and activities in the community and evaluation of the implementation of the entire service-learning project. We gather the basis for both types of evaluation during the project's implementation, so we plan how we will evaluate during the planning and design phase.



### 10.1. Evaluation of the achievement of learning objectives

As with other learning strategies, in the end, you need to evaluate what the pupils have learned while applying service-learning. Since service-learning is not a traditional teaching method, you must also adapt how you assess. As with other subjects, the objectives should be followed by thoughtful strategies to achieve the learning objectives, whether in the classroom, in service in the community, or in the assignments that students work on, and then the assessment methods should follow.

In primary education, the assessment of the achievement of learning objectives in service-learning is possible through the various activities you have included in the previous steps. The final assessment may consist of a summative assessment of individual sub-assessments for pupil outcomes, self-assessment or peer assessment. Sometimes it may be interesting to involve a community partner in the assessment if the pupils are in intensive contact with them. You may find the Assessment Plan for Achievement of Learning Objectives table and an outline of activities that you can use in assessment helpful in planning your assessment.



### Evaluation of pupils' reflections

During implementation, students write weekly reflections, journals, or short essays about their experiences during the service. They describe what they learned, how it relates to the curriculum, and how it impacted them and the community.

In reflection, the teacher or tutor may assess different knowledge or skills, depending on the focus of the reflection. For example, the teacher may assess pupils' ability to reflect on their experiences, express their thoughts, feelings, emotions, and imagination, and name what they have learned. The teacher can then work with various criteria in the assessment as an example of the evaluation of reflection that you can use. You can use a score, a verbal comment or both.

### EXAMPLE OF REFLECTION EVALUATION<sup>21</sup>



Name of pupil.....

Evaluation criterion	Possible number of points	Number of points awarded	Verbal commentary
All weekly reflections are filled	5		
Originality of ideas	5		
Length of response	5		
Depth of reflection	10		
Answering the questions asked	5		
<b>Total</b>	<b>30</b>		

### Criterion-driven observation

The teacher or community partners observe the pupils during the project and use predetermined criteria to evaluate their performance. You can use a score, verbal commentary, or both.

<sup>21</sup> Davis, Kathleen; Miller, M. David; and Corbett, Wellesley T. (1998). Methods of Evaluating Student Performance Through Service Learning. Evaluation/Reflection. 38. <https://digitalcommons.unomaha.edu/slceeval/38>

**EXAMPLE OF AN EVALUATION WITH GUIDED OBSERVATION CRITERIA 1<sup>22</sup>**



Name of pupil.....

Criterion	Possible number of points	Number of points awarded	Verbal commentary
Participation	5		
Initiative	5		
Cooperation with others	5		
Problem-solving	5		
Approach to work	5		
<b>Total</b>	<b>25</b>		

**EXAMPLE OF AN EVALUATION WITH GUIDED OBSERVATION CRITERIA 2<sup>23</sup>**



Record of observation

Observation period:

Teacher:

Project:

Behaviour	Name of pupil:	Name of pupil:	Name of pupil:	Name of pupil:
Collaboration				
Communication with others				
Motivation				
Ability to work independently				
Use of time				
Fulfilling instructions				

<sup>22</sup> Davis, Kathleen; Miller, M. David; and Corbett, Wellesley T. (1998). Methods of Evaluating Student Performance Through Service Learning. Evaluation/Reflection. 38. <https://digitalcommons.unomaha.edu/slceeval/38>

<sup>23</sup> Davis, Kathleen; Miller, M. David; and Corbett, Wellesley T. (1998). Methods of Evaluating Student Performance Through Service Learning. Evaluation/Reflection. 38. <https://digitalcommons.unomaha.edu/slceeval/38>

### Self-assessment as part of the evaluation of the fulfilment of learning objectives

In self-assessment, pupils evaluate themselves and their performance against set targets. This assessment method helps to develop critical thinking and the ability to evaluate their own learning and performance objectively.

### EXAMPLE OF SELF-ASSESSMENT<sup>24</sup>



Name of pupil.....

<p><b>I have contributed to the planning of activities.</b></p> <p>☺ ☹ ☹</p>	<p><b>I listened carefully</b></p> <p>☺ ☹ ☹</p>	<p><b>I have followed the instructions.</b></p> <p>☺ ☹ ☹</p>	<p><b>I fulfilled the agreed tasks.</b></p> <p>☺ ☹ ☹</p>
<p><b>I helped another classmate.</b></p> <p>☺ ☹ ☹</p>	<p><b>I have worked with others.</b></p> <p>☺ ☹ ☹</p>	<p><b>I appreciated the work of others.</b></p> <p>☺ ☹ ☹</p>	<p><b>I have shared my views.</b></p> <p>☺ ☹ ☹</p>
<p><b>I took notes and records.</b></p> <p>☺ ☹ ☹</p>	<p><b>I asked for help when I needed it</b></p> <p>☺ ☹ ☹</p>	<p><b>I can name what I learned in the project.</b></p> <p>☺ ☹ ☹</p>	<p><b>I know that the opinion of others is as important as mine.</b></p> <p>☺ ☹ ☹</p>

### Peer-assessment as part of the evaluation of the fulfilment of learning objectives

In peer assessment, pupils evaluate their classmates based on predetermined criteria. This activity promotes the ability to evaluate the performance of others and give feedback. In peer evaluation, each learner rates each member of their group or class according to how each has contributed to and helped to meet the objectives of the service-learning project.

You can set the criteria as the teacher or by the class. The number of criteria should not be high. Whatever criteria you or the pupils set must be understood by all pupils so that each pupil can use the criteria appropriately. The class then will use these criteria to assess the performance of individual pupils. For the assessment, we recommend forming smaller groups of pupils who know each other well because assessing 20-25 children in a class would be complicated for the children.

<sup>24</sup> Davis, Kathleen; Miller, M. David; and Corbett, Wellesley T. (1998). Methods of Evaluating Student Performance Through Service Learning. Evaluation/Reflection. 38. <https://digitalcommons.unomaha.edu/slceeval/38>

You can conduct peer reviews on an ongoing basis or at the end of the project. After each student has rated each student in the class or group, add the scores and divide by the number of raters. This will determine the average score for each pupil in the group.

## EXAMPLE OF PEER EVALUATION IN A SERVICE-LEARNING PROJECT <sup>25</sup>



Evaluation in the group

**The name of the student assessing:**

Try to rate the children in your group according to the following criteria:

1. Performs assigned tasks
2. Cooperates with others
3. Uses time efficiently
4. Wants to learn new things

Using the scale, give points to each person

Scale: 1 very good    2 good    3 average    4 poor    5 very poor

Name of whom you are evaluating	Performs assigned tasks	Cooperates with others	Uses time efficiently	Wants to learn new things
---------------------------------	-------------------------	------------------------	-----------------------	---------------------------

Resulting assessment: Add up the group assessment for each pupil and divide by the number of children who assessed him/her.

Child's name	Evaluation score (sum of all points)	Number of evaluators	Average (sum of all scores/number of evaluators)
--------------	--------------------------------------	----------------------	--

Evaluation of project work and presentations

At the end of the project, pupils produce a project report or output summarising their work, results and contribution to the community. This can be a presentation, video, collage, or poster. Again, set the assessment criteria according to what the pupils are expected to learn. Through the production of written presentations, develop visual and reading literacy.

<sup>25</sup> Davis, Kathleen; Miller, M. David; and Corbett, Wellesley T. (1998). Methods of Evaluating Student Performance Through Service Learning. Evaluation/Reflection. 38. <https://digitalcommons.unomaha.edu/slceeval/38>



## Evaluation of student portfolios from a service-learning project

Portfolio assessment is one of the appropriate ways to evaluate the achievement of learning objectives in service-learning. Portfolios allow learners to become aware of their learning abilities and to participate directly in assessing their progress. A portfolio is a collection of learner products documenting activities, learning, and contributions to the community. A portfolio can document the process and outcomes of a pupil's learning. Individual pieces of work can be placed in binders by pupils. A pupil portfolio for a service-learning project may include written examples of planning meetings, meeting agendas, project plans, budgets, job descriptions and responsibilities, evaluations, journals, feelings about the project, essays, team ideas, problems, research and solutions, rough drafts and finished products, assessment results of specific tasks related to skills learned through service, artwork, evidence of *community-school* collaboration, articles about the project, awards, testimonials from participants, families, service recipients, interviews with families, self-evaluation, peer-evaluation.

Think about the following points when assigning portfolios to pupils:

- Explain to the children what the purpose of the portfolio is.
- Let the children think about the design of the portfolio.
- Determine how the portfolio will be evaluated and what criteria will be used.
- Involve pupils—allow them to actively participate in the process of choosing what to include in their portfolio.
- Include a cover letter at the beginning of the portfolio, giving relevant information about the pupil, the school and the project, the purpose of the portfolio.
- Explain that a portfolio is a *work in progress*. Students may add, improve, remove, revise, edit, or discard items as it evolves.

### **Portfolio assessment**

The portfolio is evaluated based on completeness, quality of content, reflection, and connection to curriculum and objectives. Using assessment rubrics, portfolio assessments should include a fixed scale for each performance standard. The primary function of rubrics is to provide well-defined criteria for scoring individual portfolios. There are several types of rubrics that you can use or modify to suit your needs. Before you begin scoring portfolios, consider the characteristics of student performance and list them. You can modify the rubrics to suit your individual needs.

## EXAMPLE OF AN ASSESSMENT OF A STUDENT PORTFOLIO FOR A SERVICE-LEARNING PROJECT



This example of assessing a student's portfolio includes assessing its structure and aesthetic design, as well as the depth of reflection that the student demonstrates in their learning and personal growth.

### 4: More than adequate portfolio

**Structure and quality:** The portfolio is excellently structured and organised, with a clear division of parts and impeccable visual design. It contains all the necessary information logically, making it easy to read and understand.

**Reflection:** The learner demonstrates deep self-awareness, critically evaluates their progress and identifies specific ways in which he/she has improved. The reflection includes detailed examples demonstrating the learner's personal growth and understanding of the project's impact.

### 3: Adequate portfolio

**Structure and quality:** The portfolio is well structured and organised, with minor shortcomings in organisation or visual design. It contains all relevant information, although some sections could be better linked.

**Reflection:** The learner provides a meaningful reflection demonstrating an understanding of their progress and personal growth, but some parts could be more profound or better connected to specific experiences.

### 2: Less than adequate portfolio

**Structure and quality:** The portfolio is structured but may be cluttered or incomplete, with visible deficiencies in organisation or layout. Some critical information may be missing or poorly presented.

**Reflection:** The learner provides a superficial reflection that only partially recognises personal growth or learning. Reflection is general and contains few specific examples or evidence of self-awareness.

### 1: Very poor portfolio

**Structure and quality:** The portfolio is disorganised, poorly structured, and has significant visual design flaws. Much important information is missing or incomprehensible.

**Reflection:** Reflection is very superficial, with no demonstrable personal growth or self-awareness. There are no concrete examples or more profound understanding of the project experience.

### 0: No portfolio or completely off task:

**Structure and quality:** The portfolio is either completely lacking or so deficient that it is unfit for purpose. The information is disjointed or insufficient.

**Reflection:** Reflection is absent or so superficial that it does not demonstrate personal growth or learning.



## 10.2. Evaluation of a service-learning project

In addition to evaluating the learning objectives, it is necessary to evaluate the achievement of the service-learning objectives and other aspects of service-learning project implementation, such as teamwork, collaboration with the community, teacher support and guidance, and many others. It is ideal if this evaluation is participatory and if it involves the different stakeholders: the learners, the teacher and the community partners. Again, we stress that evaluation is closely linked to reflection, especially at this final point. We offer tips for final activities that offer the opportunity to look back on the project and evaluate different parts of it.

## ACTIVITY: STICKERS FOR THINKING - FINAL EVALUATION OF THE PROJECT<sup>26</sup>

**Aim:** To reflect and evaluate the activities carried out during the project from different perspectives, focusing on teamwork and the individual contribution of the participants.



**Materials:** flipchart paper (6 sheets), markers, sticky notes in different colours (white, red, yellow, pink, green, blue)

### Procedure for the teacher:

**Preparation:** The teacher glues 6 flipchart papers side by side and places them on the floor. On the flipchart, the teacher writes the meaning of the colours of each sticker that the pupils will use. The colours of the stickers and their meanings:

- **White:** Record the facts, figures and information you remember from the project.
- **Red:** Express the feelings and emotions you experienced during the project.
- **Yellow:** Focus on the positive things that happened during the project.
- **Pink:** Identify your contributions during the project.
- **Green:** Write down creative thoughts and ideas that were interesting or new to you.
- **Blue:** Summarise the conclusions you have reached during the project.

**Process:** The teacher hands out slips of paper in the colours representing each thinking category. Pupils sit around the flipcharts and reflect on the project. Each of them, in turn, writes their thoughts on the corresponding-coloured slips of paper. After completing the slips, the pupils stick them on the appropriate flipcharts.

**Discussion:** The teacher then leads a discussion based on the individual slips sorted by colour. Pupils can comment on each other's contributions and develop a debate about what they have learned, what they liked and what they could improve in the future.

<sup>26</sup> Centre for European Volunteering. (2022). [Service learning upscaling social inclusion for kids – Toolkit](#).

## ACTIVITY: PROJECT CRUISE RETROSPECTIVE<sup>27</sup>

**Aims:** To summarise the critical moments of the service-learning project, to name the successes and obstacles of the project and to evaluate the team's functioning.



**Materials needed:** flipchart paper, papers, crayons, markers, papers with symbols: wind, lifebuoy, anchor, fish and ice floe.

### Procedure for the teacher:

**Drawing the river:** Divide the pupils into small groups. Invite pupils to complete a year-long service-learning journey as a river on flipchart paper. Have them draw on the river, how time passed, and how they progressed from the beginning (the source of the river - the first introduction to service learning) to the end of the project. Have the children draw if the river meanders in any part, if rapids appeared somewhere, if other rivers flowed into the river, if there was a strong current in any part, or if there seemed to be a dead end.

**Drawing a boat:** Invite students to describe their team as a boat. Give them another smaller piece of paper and invite them to draw a boat together. The following questions may help the pupils:

- What does the boat look like?
- Is that a sailboat? Or is it a steamer? Is it a small boat or a raft?
- What is the ship powered by?
- How long a voyage is the ship going on?
- Who is on board?

**Drawing the flag:** Ask pupils, "What flag are you flying?" Have the group draw the flag of their ship. This question may help them: "What is your main theme/vision?" Place the boat with the flag on the river.

Hand out the symbol cards and have the pupils place them in the river and comment on them. Write the supporting questions on the board or flipchart paper and place it where all pupils can see it.

- WIND: What put the wind in your sails? Who or what gave you the motivation?
- RESCUE CIRCLE: When and why did you need a rescue circle? When did you need help?
- ANCHOR: What anchored you? What helped you stabilise the situation?
- FISH: What catch do you value the most? When have you experienced success?
- ICE CREEK: When did you hit a snag?

<sup>27</sup> Ambrozyová, V., Janičinová, B., Svatá, K., et al. (2019). *Metodika programu Active Cinizens pro 2. stupeň základních škol. Člověk v tísni, o.p.s.*



Summarise what the cruise looked like according to the students and you. Appreciate the obstacles they overcame, remember to mention the shortcomings too, but approach them so that you can learn from them and improve. Appreciate what they did well and how they stood up as a team and worked together. At the same time, do not forget to mention outcomes that they can build on.

Evaluate the project's impact on the target group and suggest a way forward. Ask participants if they think they have been able to help the target group. What impact did the project have? What else should or could have been done? It is also worth noting that change is often an ongoing process, not usually achieved in one action. Even if some things are not right the first time, lessons can be learned through reflection and evaluation.

## ACTIVITY: MY PLACE ON THE BOARD<sup>28</sup>

**Aims:** To become aware of their team role and evaluate their work.

**Materials needed:** enough cards with the following words: captain, crew member, passenger, a prisoner in the hold, helmsman, pirate; A4 sheets, cardboard



**Procedure for the teacher:**

Introduce the roles they played in the project. Spread the role cards (see handout) on the floor and have students look at all the crew members. Ask them what role they played on the team boat. Which crew member best describes them concerning the project? If any roles are missing, you and the pupils can fill them in.

Invite pupils to choose a role card that describes them and sit in a circle.

Ask students to think about the following questions. Write the questions on the board so they have them before them. Pupils can comment orally or use the free writing method to compare their answers.

- Why did they choose this crew member?
- How did you feel in this role?
- Did you choose this role yourself?
- Is there anything you would like to change? To be in a different role?

Invite pupils to appreciate each other. Stick a sheet of A4 paper on each pupil's back. Tell the pupils that they now have the opportunity to write on this paper the awards they deserve for their work. Invite them to be specific.

Thank them for knowing their roles on the team. Tell students that each crew member is essential and contributes to a smooth sailing to the finish line. At the same time, stress that even a prisoner or pirate can contribute something - they can realise their limitations and shortcomings and try to turn them into opportunities or find another ship that will sail in a different direction with a different wind in its sails.

---

<sup>28</sup> Ambrozová, V., Janičinová, B., Svatá, K., et al. (2019). *Metodika programu Active Cizens pro 2. stupeň základních škol*. Člověk v tísni, o.p.s.

## ACTIVITY: TRAFFIC LIGHTS<sup>29</sup>

**Aims:** To encourage deep reflection on the project, identify factors that influenced the success or failure of the project and suggest improvements for future initiatives.



**Materials needed:** Poster in three colours: green, yellow, and red; writing utensils (markers, pens); stickers or sticky notes for writing reminders.

### Procedure for the teacher

**Grouping:** Divide participants into smaller groups (e.g. pupils, teachers, community members).

**Discussion and identification of factors:** Each group discusses three essential items:

- Green Light: 3 factors that facilitated project development.
- Yellow light: 3 factors that should be improved or strengthened to achieve better results.
- Red light: 3 factors that should be reduced or eliminated to ensure results in new projects.

Each group sticks their written comments on the corresponding coloured boards (green, yellow, red).

**Joint reflection:** The groups read the contributions of the other groups. They discuss the similarities and differences in views. They identify common themes and suggest improvements.

Alternative triads:

You can adapt the activity to different themes, for example:

- 3 aspects that participants learned.
- 3 aspects they would like to know more about.
- 3 activities that worked well,
- 3 activities that require adjustments,
- 3 facts that should not be repeated.

<sup>29</sup> Sosa Rolón, A. J. (2020). [Resource book for the development of service-learning projects](#). CLAYSS.

## 11. Celebration

Celebration is a stage in which pupils can present their achievements at a public event open to the local community to recognise and celebrate them. The celebration has significance for the different parties involved in the project:

- Pupils can show what they have learnt and achieved and receive recognition.
- For the community or partners, the celebration is a moment of realising that the project has ended. It is also a moment to say thank you and goodbye.
- For families, sponsors, other people or organisations involved, it can be a moment when they understand exactly what their support means to the community and the pupils. Seeing the direct results can help them feel proud and encourage them to offer support or engage in similar activities again.
- This is a great opportunity for the school to inform people about the project, the learning they are applying, and their impact on the community.
- It is an opportunity for the public to learn about the project and ways in which they could get involved and support similar activities.



The details of the celebration should depend on their decision, but of course, resources and capacity should also be considered.

The celebration can take the form of:

- Exhibitions of photographs taken during the project.
- Showing a video of the project in progress or something related to the topic.
- A concert or artistic moment in which the direct recipients show their gratitude or introduce themselves.
- A small gathering where they enjoy a pizza or snack together.
- Virtual event.

When planning a celebration, think about the timing, the program, the venue and the organising team.

### UPDATE

The moment the pupils choose to celebrate is critical and requires a little planning. The event should come after the activity is over. It should be early enough so that the public does not forget about the project, but the pupils should also be able to evaluate the project to prepare to present the results. Pupils should also ensure that the people they want to invite to the event are available at that time and will attend. They should send invitations well in advance.

## PROGRAMME

They should not be absent from the programme:

- presentation of the results achieved within the project,
- recognition of pupils, e.g. by handing out certificates
- Thanks to partners and all involved.

## EXAMPLE OF AN EVENT PROGRAMME TO CELEBRATE A STUDENT SERVICE-LEARNING PROJECT<sup>30</sup>



Depending on the project, you can lengthen or shorten the individual parts.

15:00 The teacher will welcome all participants and introduce the pupils.

15:10 Pupils will present the project and its results:

- Why they decided to implement the project
- What activities have they implemented
- What they have achieved
- What they have learned

15:30 Pupils will thank community partners and everyone who contributed to the project.

15:35 Pupils and students invite participants to view photos from the project or video

15:55 The teacher thanks the pupils, hands out certificates, talks about plans for the continuation of the project and thanks them for their participation.

16:00 Do not forget to take a photo together.

## LOCATION

Like the other options, the choice of venue should be tailored to the audience you are expecting at the event and the project. The venue can be a school or a place where the project was implemented.

## ORGANISATIONAL TEAM

Although this is an event for the pupils as much as for everyone else, this does not mean they should not be involved in the planning and organisation of the celebration. By including them and their preferences, you will ensure that they enjoy it as much as possible. Of course, as a teacher, you can keep some things from them so that they can enjoy some surprises.

---

<sup>30</sup> Roots and Shoots. (2017). [Roots and Shoots Toolkit](#).

## ACTIVITY: GALLERY WALK - PLANNING THE FINAL EVENT<sup>31</sup>

**Aim:** To help pupils develop teamwork, reach a consensus and plan a final celebration together.

**Material needed** A4 paper, large chart paper, pens, markers of different colours, adhesive tape



### Procedure for the teacher:

**Introduction:** Explain to the pupils the aim of the activity, which is to plan the project's final event together. Inform them that they will work in groups and visit different stations to share and develop their ideas.

**Write incentives:** Create six incentives related to the final event (e.g. WHO will participate? WHEN and WHERE will it be held? WHAT will the event look like? WHAT activities will be part of it?). Write each suggestion on a piece of chart paper and post them in different places in the classroom to create six stations.

**Group work:** Pupils are divided into small groups, and each group starts at one of the stations. They read the stimulus and write their answers, thoughts, and comments on the board paper. Each group uses markers of different colours to see which groups have added which ideas. After 5 minutes, the groups move to the next station. They read the previous group's answers and added their ideas. This process continues until all groups have visited each station.

The teacher monitors how the groups work and provides help or guidance to ensure that the students understand the stimuli correctly and that the discussion moves in the right direction.

**Reflection:** After completing the gallery walk, each group returns to their starting point and reads all the completed answers. Then, the whole class gathers and discusses all ideas together to reach an agreement on the details of the final event. Pupils divide responsibilities and set a timetable for completing the celebration preparations.

<sup>31</sup> Centre for European Volunteering. (2022). [Service learning upscaling social inclusion for kids – Toolkit](#).

## ACTIVITY: UNIQUE PHOTO OF PARTICIPANTS

**Aim:** To reinforce the group's identity, celebrate the project's achievements, and provide visual documentation of all involved parties' participation and involvement.



**Materials needed:** camera, smartphone, or portable tripod for better photostability.

### **Procedure for the teacher:**

The group photo is a traditional part of the project, and there is a reason for that: it is essential to see the whole group together, sharing in the celebration of the project. This photo can also be displayed on the school bulletin board or published in the school magazine. Do not forget all the participants: pupils, teachers, authorities, community partners, collaborating organisations or families, local institutions, etc.

## References:

Ambrozová, V., Janičinová, B., Svatá, K., et al. (2019). *Metodika programu Active Cinizens pro 2. stupeň základních škol. Člověk v tísní*, o.p.s.

Britannica, T. Editors of Encyclopaedia. (2024, May 24). Elementary education. *Encyclopedia Britannica*. <https://www.britannica.com/topic/elementary-education>

Brozmanová Gregorová, A., Bohdanová, S., Harváneková, I., Horvatovič, L., Kubišová, L., Kurpielová, M., Milková, M., Nemcová, L., Ondrášik, M., Sabo, R., Šolcová, J., & Tomková, L. (2019). *Cesty k dobrovolnictvu. Metodika výchovy a vzdělávání dětí a mládeže k dobrovolnictvu*. Stupava: Platforma dobrovolnických centier a organizací.

Brozmanová Gregorová, A., Heinzová, Z. Uhláriková, J. (2023). *Service learning ako forma odbornej praxe v pomáhajúcich profesiách*. Belianum.

Centre for European Volunteering. (2022). *Service learning upscaling social inclusion for kids – Toolkit*.

Davis, Kathleen; Miller, M. David; and Corbett, Wellesley T. (1998). Methods of Evaluating Student Performance Through Service Learning. Evaluation/Reflection. 38. <https://digitalcommons.unomaha.edu/slceeval/38>

Fox, K. R. (2010, January 1). Children making a difference: Developing awareness of poverty through service learning. *Taylor & Francis*, 101(1), 1–9. <https://doi.org/10.1080/00377990903283965>

Hall, R., Drál, P., Fridrichová, P., Hapalová, M., Lukáč, S., Miškolci, J., & Vančíková, K. (2019). *Analýza zistení o stave školstva na Slovensku: To dá rozum*. Bratislava: MESA10. Dostupné na Retrieved from: <https://analiza.todarozum.sk>

Jacoby, B. (2015). *Service-learning essentials: Questions, answers, and lessons learned*. San Francisco: Jossey-Bass.

Lake, V. E., & Jones, I. (2008, November 1). Service-learning in early childhood teacher education: Using service to put meaning back into learning. *Elsevier BV*, 24(8), 2146–2156. <https://doi.org/10.1016/j.tate.2008.05.003>

Lucas-Mangas, S., & Martínez-Odría, A. (2012). La implantación y difusión del aprendizaje-servicio en el contexto educativo español: Retos de futuro de una metodología de enseñanza-aprendizaje para promover la innovación en la educación superior. *Revista del Congrés Internacional de Docència Universitària i Innovació (CIDUI)*, 1(1). Retrieved from <https://goo.su/7gwcD>

Lucas Barcia, E. M., Díaz-Arias, A. O., García Barrera, A., & Roa González, J. (2024). Implementation of service-learning in Madrid primary schools. *Journal of Higher Education Theory and Practice*, 24(4). <https://doi.org/10.33423/jhetp.v24i4.6952>

Martínez-Odría, A. (2007). Service-learning o aprendizaje-servicio: La apertura de la escuela a la comunidad local como propuesta de educación para la ciudadanía. *Bordón. Revista de pedagogía*, 59(4), 627–640. Retrieved from <https://goo.su/peE3n>

Oravcová, J. (2015). *Vybrané kapitoly z vývinovej psychológie*. Banská Bystrica: PF UMB, OZ Pedagóg.

Paredes, D. M., & Martínez, D. R. (2016, May 23). Aprendizaje-servicio: Una práctica pedagógica que promueve la participación del estudiantado para la mejora escolar y social.

Complutense University of Madrid, 28(2), 555–571.  
[https://doi.org/10.5209/rev\\_rced.2017.v28.n2.49623](https://doi.org/10.5209/rev_rced.2017.v28.n2.49623)

Puig-Rovira, J. M., Gijón, M., Martín, M. J., & Rubio, L. (2011). Aprendizaje-servicio y educación para la ciudadanía. *Revista de educación*, 1, 45–67. Retrieved from <https://goo.su/C5KOHp7>

Richards, M. H., Sanderson, R. C., Celio, C. I., Grant, J. E., Choi, I., George, C., & Deane, K. (2013, March 1). Service-learning in early adolescence. *SAGE Publishing*, 36(1), 5–21.  
<https://doi.org/10.1177/1053825913481580>

Roots and Shoots. (2017). [\*Roots and Shoots Toolkit\*](#).

Sosa Rolón, A. J. (2020). [\*Resource book for the development of service-learning projects\*](#). CLAYSS.

UNESCO Institute for Statistics. (2012). *ISCED 2011* (PDF). "Annex III". Archived from the original (PDF) on June 24, 2017.

Watson, D. L., Hueglin, S., Crandall, J., & Eisenman, P. (2002, May 1). Incorporating service-learning into physical education teacher education programs. *Taylor & Francis*, 73(5), 50–54.  
<https://doi.org/10.1080/07303084.2002.10607810>

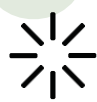
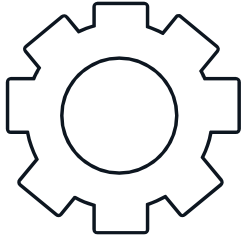

# Third part: Workbook for children – selected activities

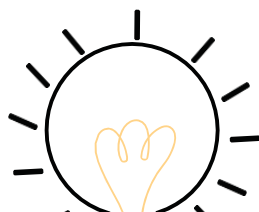

# My Service-learning workbook

My name:.....

My class:.....

My teacher.....

My helping hand

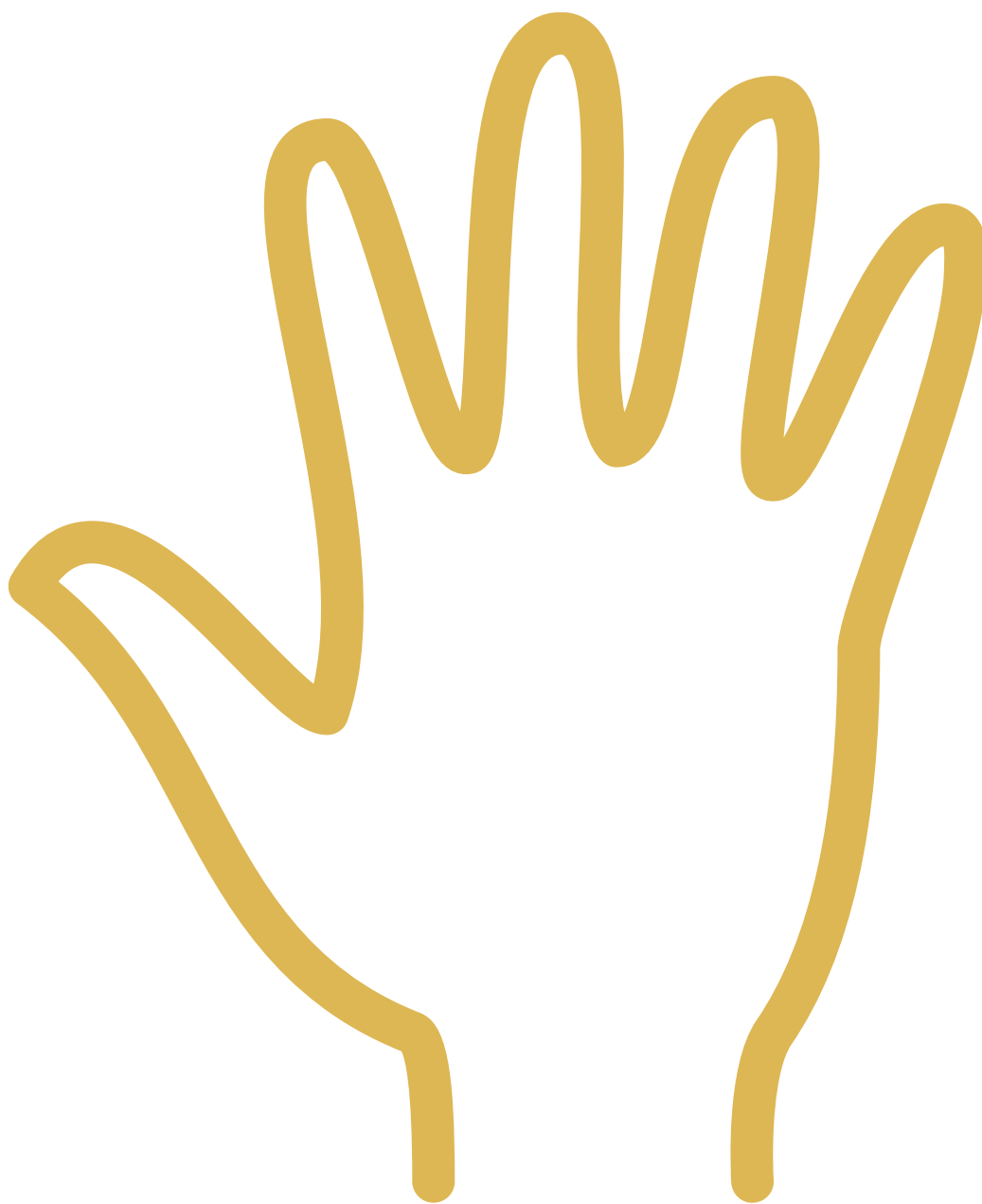

# What I want to do in service-learning

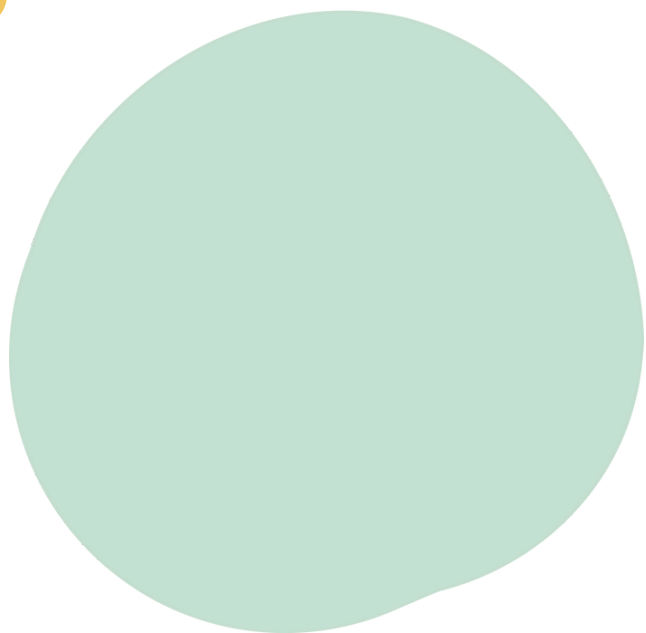

# What I want to learn in service-learning

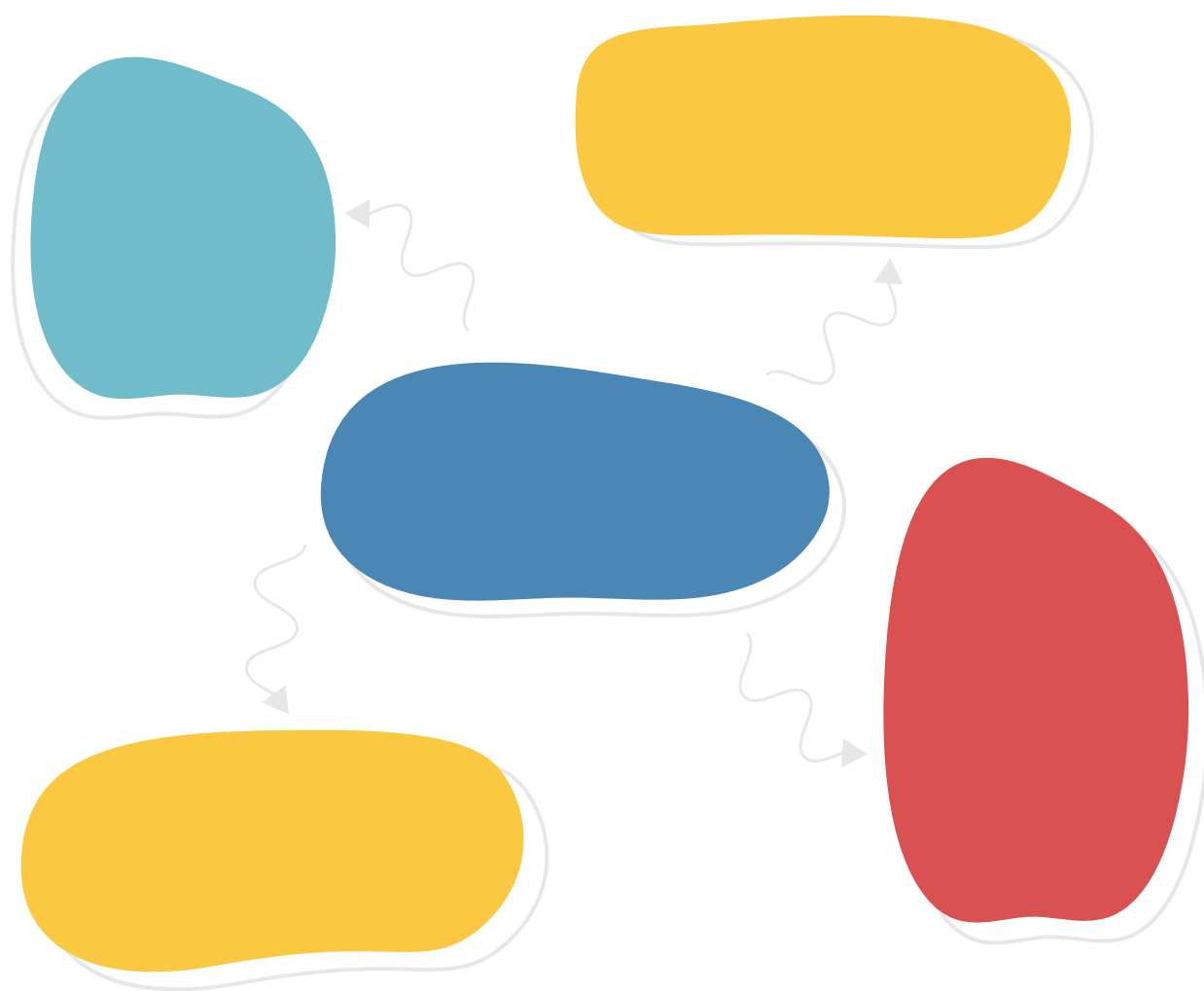

# Our rules



# My community

# My community

# Community map



# Our questions for community survey

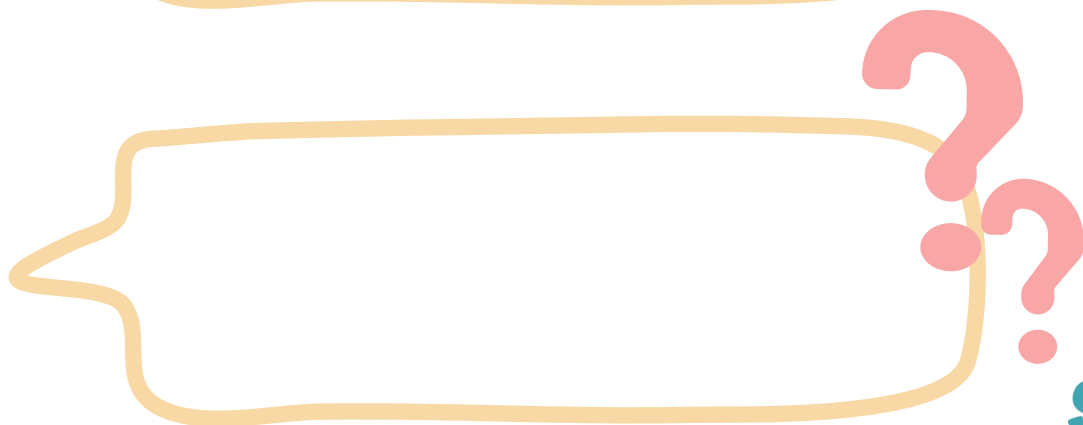

# Problem tree

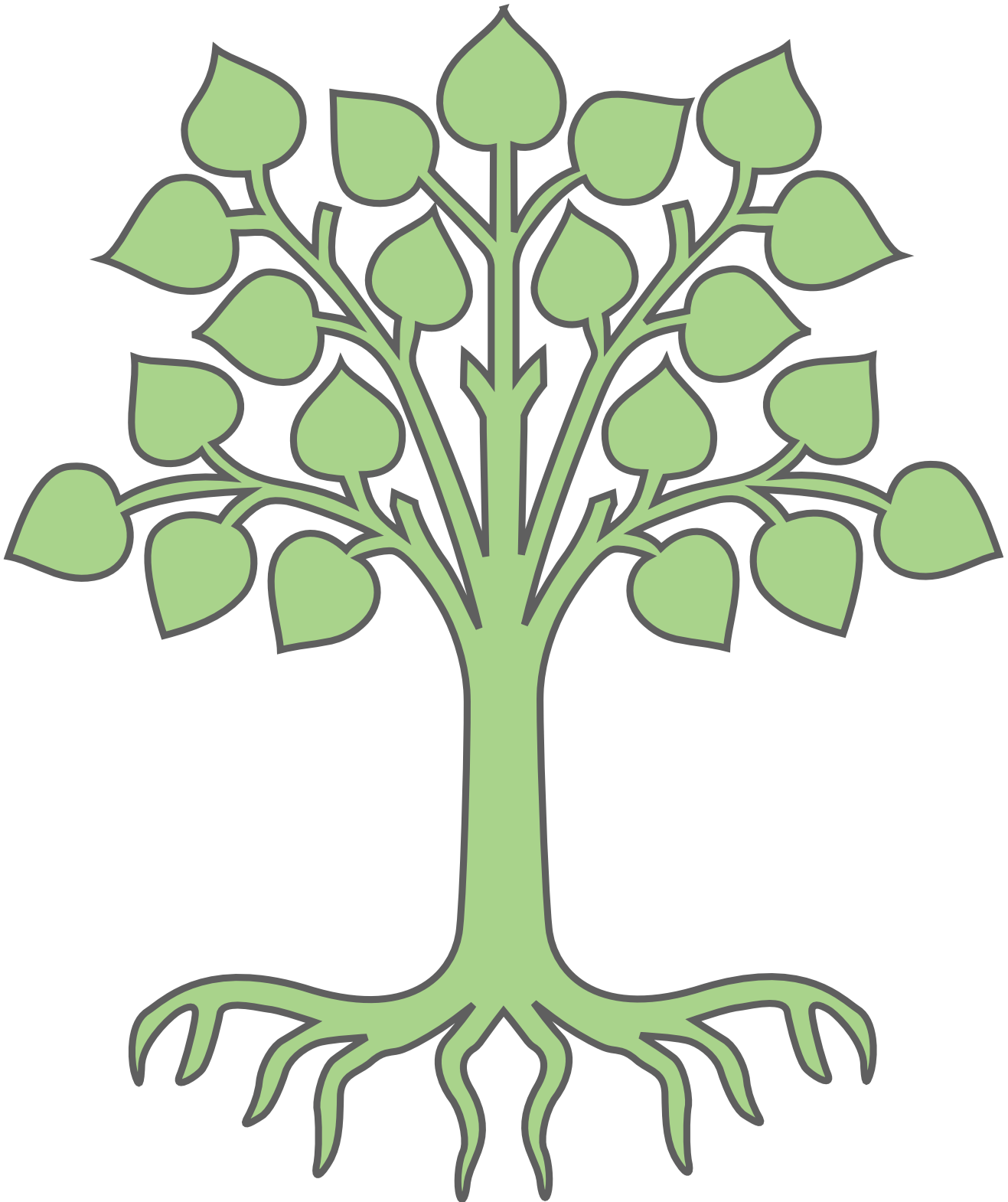

# Goal tree

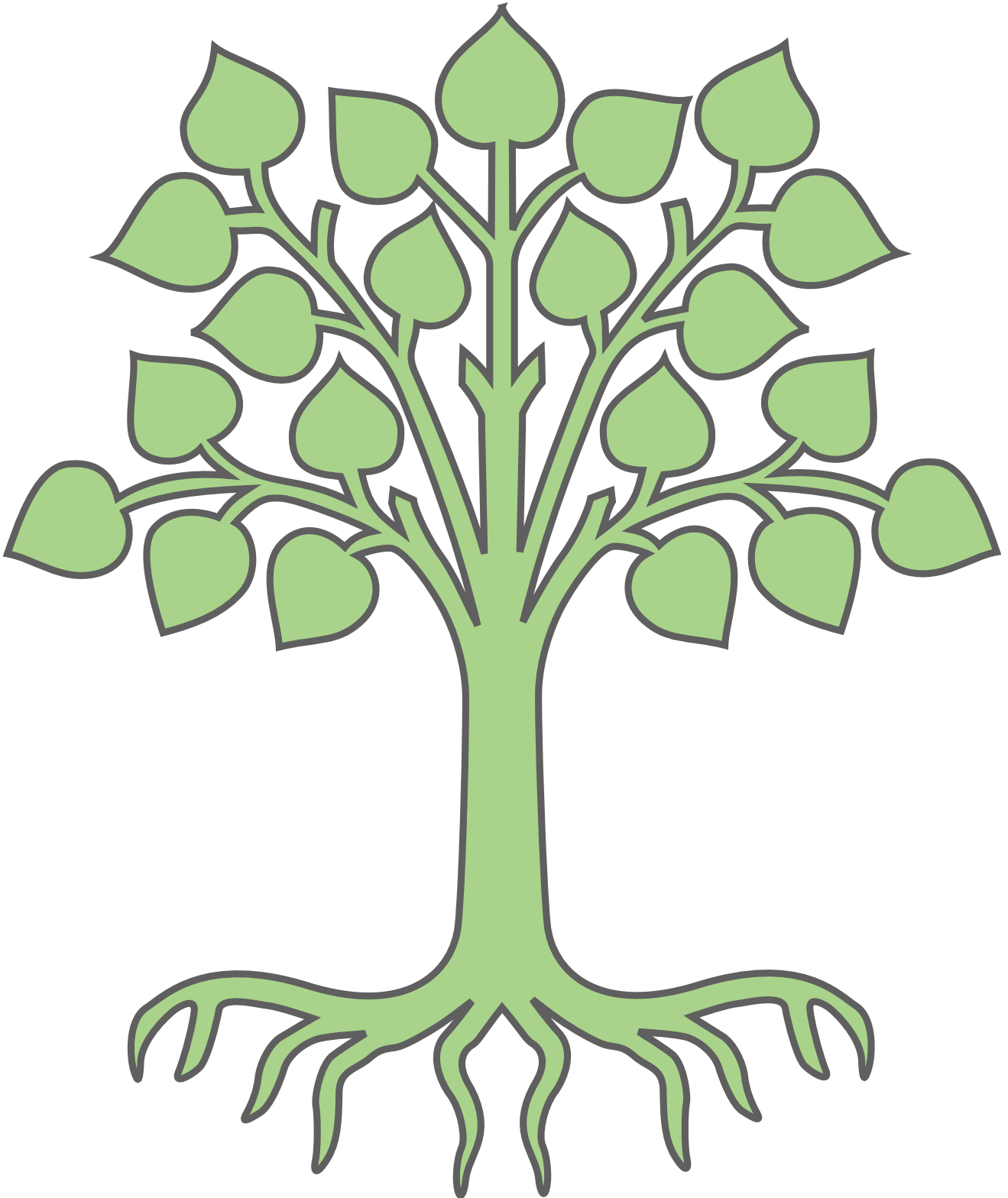

# Goal tree

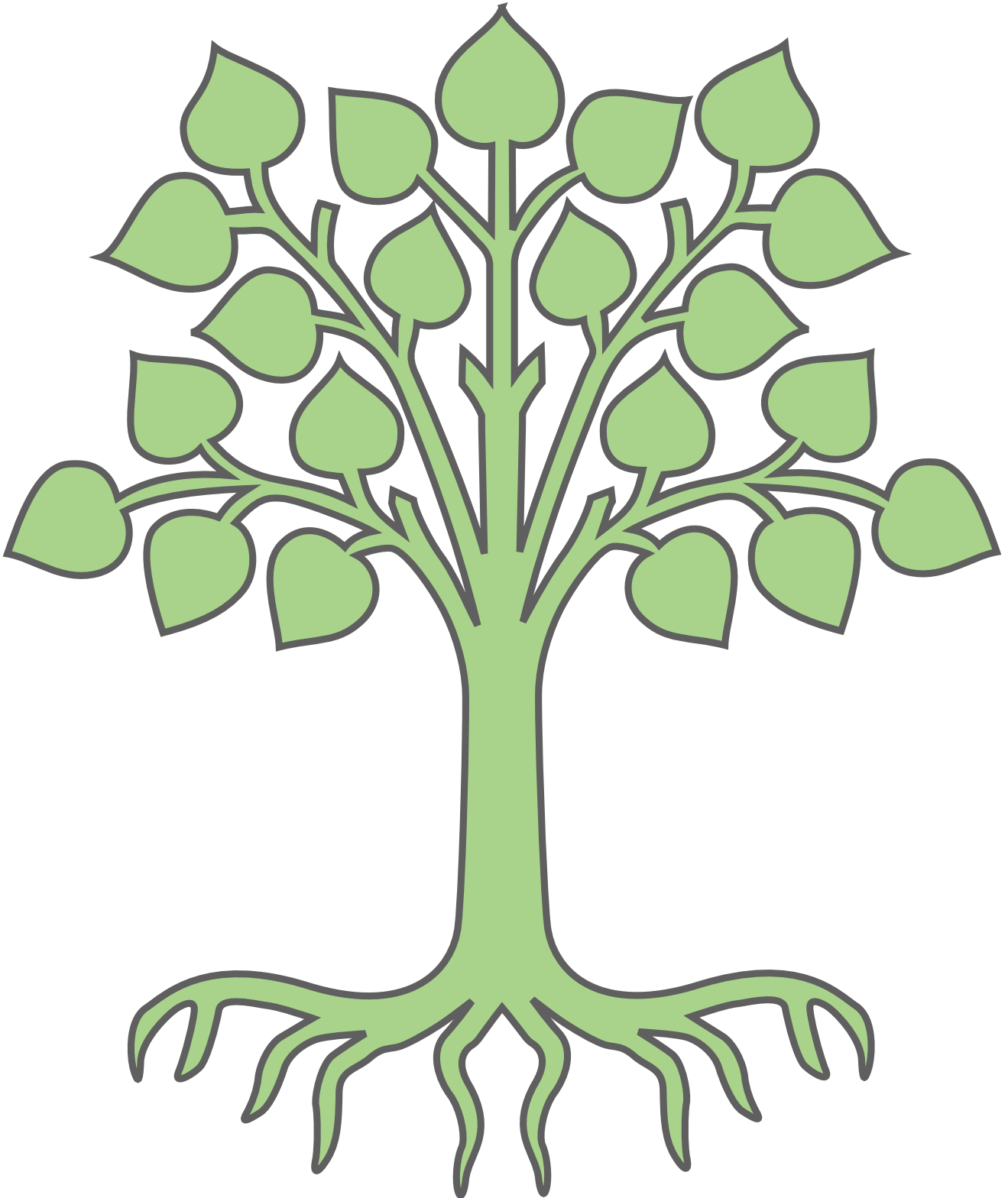

# Crossing the bridge

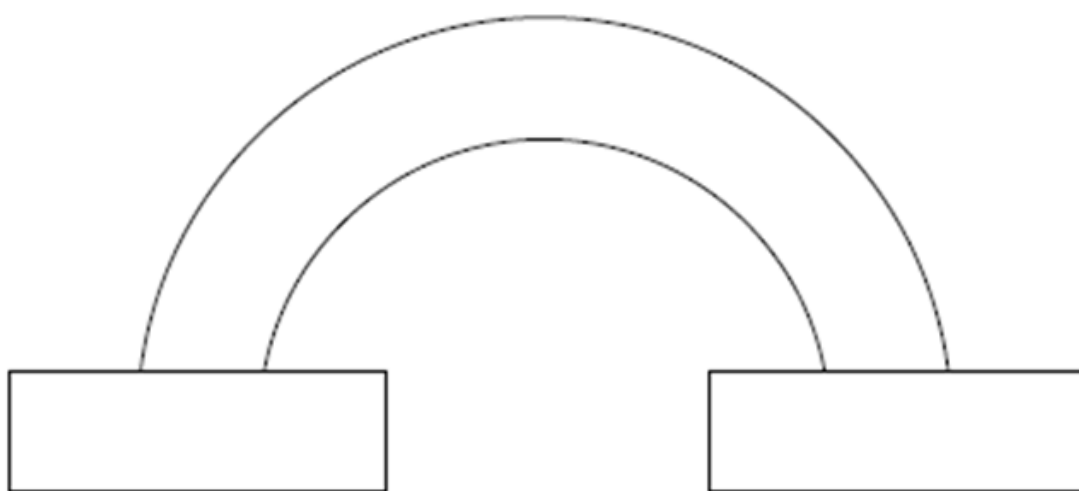

# Crossing the bridge

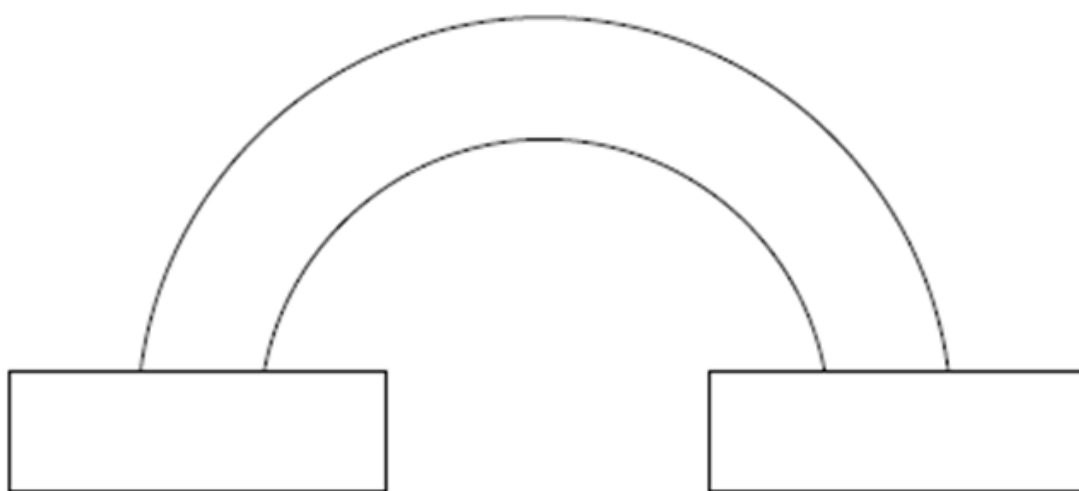

# Our timeline

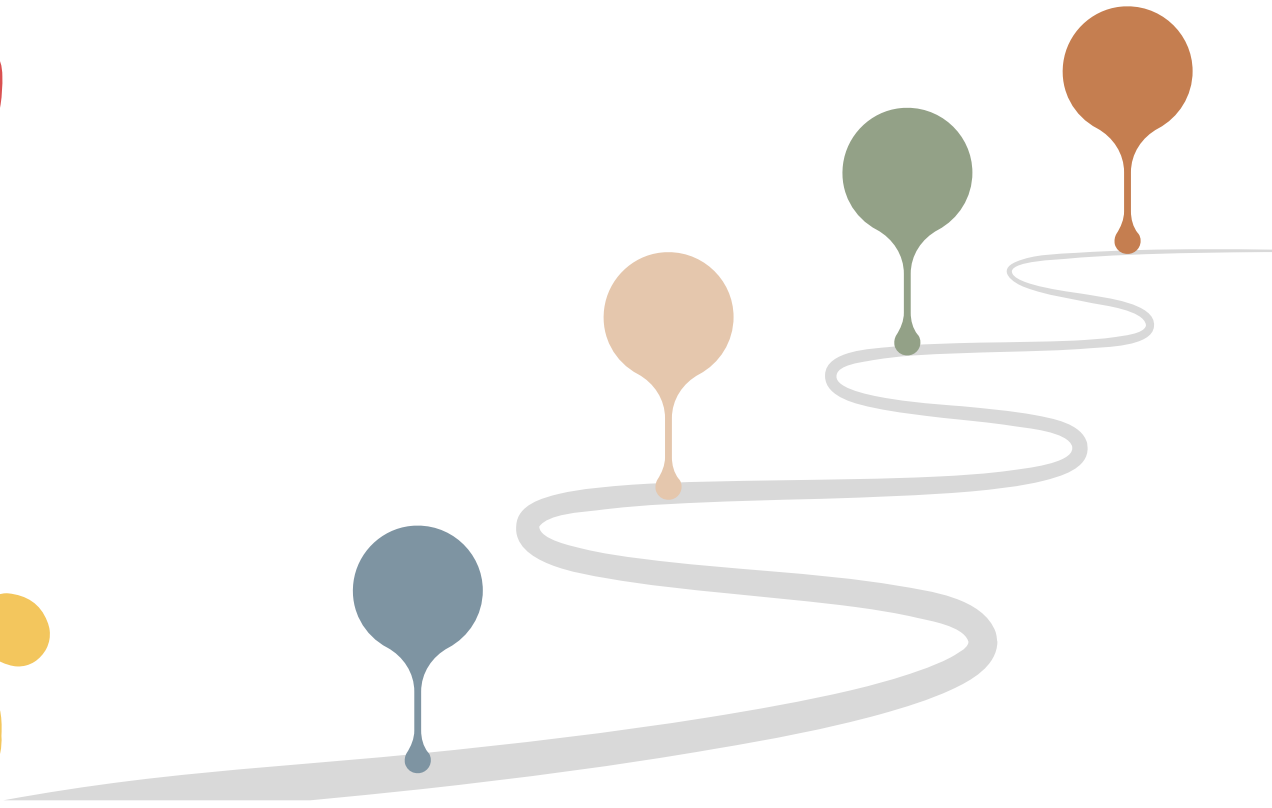

# Project plan

# CHECKLIST FOR PLANNING A SERVICE-LEARNING PROJECT

- Did we get the community needs right?
- Is it essential for the community?
- Have we involved the community in assessing their needs?
- Have we defined the service objectives?
- Are the goals of the service related to the need?
- Have we set learning objectives?
- Are learning and service objectives related?
- Are the planned activities related to the objectives?
- Have we divided responsibilities and roles in the team?
- Have we made a timetable?
- Do we have a budget for each activity?
- Do we have the resources to implement the project?
- Do we have a plan for monitoring and evaluation of the project?
- Do we have a plan to promote the project?



# THIS WEEK

What did I like this week?

What was complicated for me this week?

---

---

How did I help in the project this week?

---

---

What did I learn this week?

---

---

# Five fingers

Have you discovered anything new about yourself? If so, what is it?

What is the most important thing you have learned?

What didn't you like?

What small details appealed to you the most during the project?

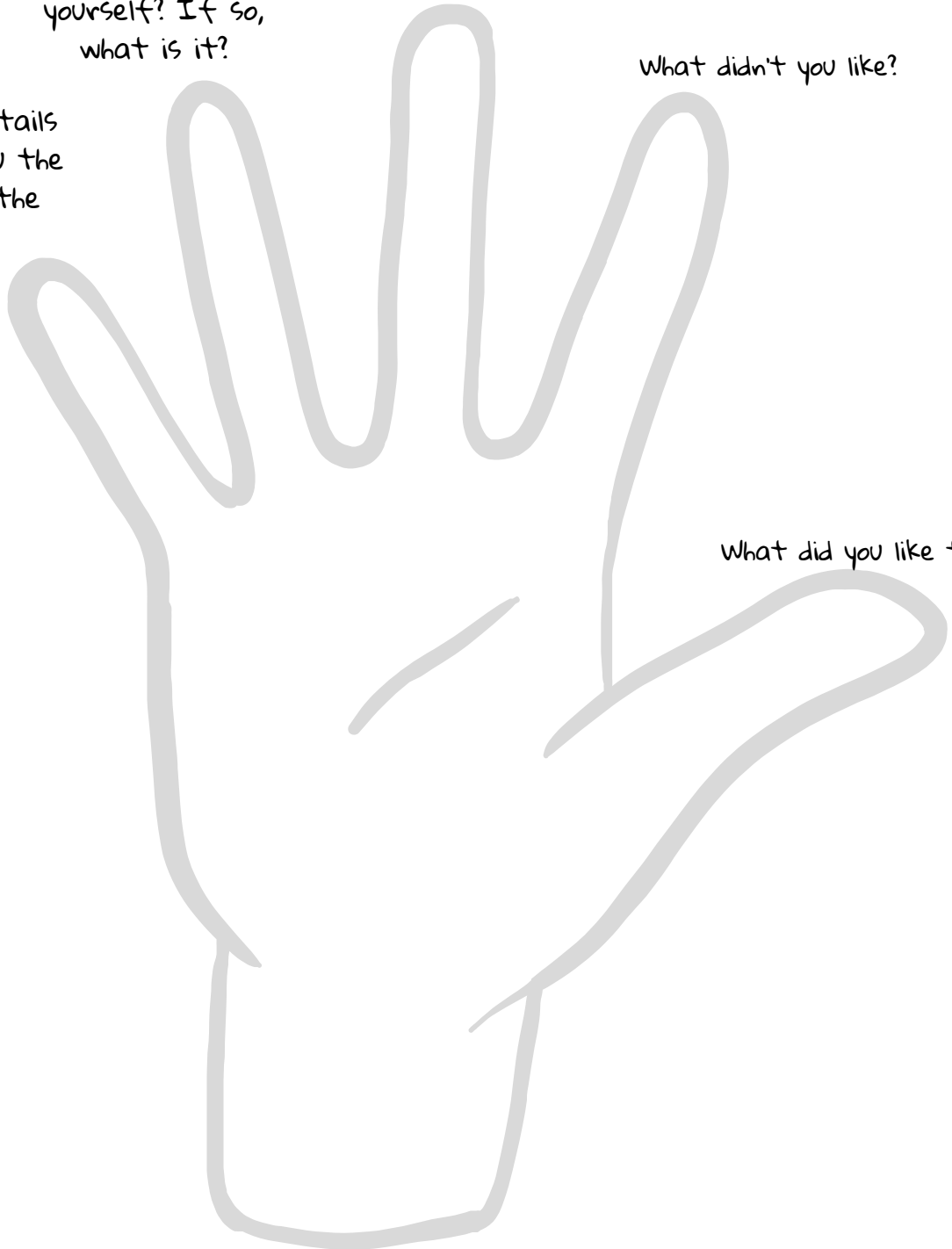

What did you like the most?

# How I helped

# What I have learned

# My feelings in the rainbow



# My self-assessment

<p>I have contributed to the planning of activities.</p> <p><input type="radio"/> <input type="radio"/> <input type="radio"/></p>	<p>I listened carefully</p> <p><input type="radio"/> <input type="radio"/> <input type="radio"/></p>	<p>I have followed the instructions.</p> <p><input type="radio"/> <input type="radio"/> <input type="radio"/></p>	<p>I fulfilled the agreed tasks.</p> <p><input type="radio"/> <input type="radio"/> <input type="radio"/></p>
<p>I helped another classmate.</p> <p><input type="radio"/> <input type="radio"/> <input type="radio"/></p>	<p>I have worked with others.</p> <p><input type="radio"/> <input type="radio"/> <input type="radio"/></p>	<p>I appreciated the work of others.</p> <p><input type="radio"/> <input type="radio"/> <input type="radio"/></p>	<p>I have shared my views.</p> <p><input type="radio"/> <input type="radio"/> <input type="radio"/></p>
<p>I took notes and records.</p> <p><input type="radio"/> <input type="radio"/> <input type="radio"/></p>	<p>I asked for help when I needed <u>it</u></p> <p><input type="radio"/> <input type="radio"/> <input type="radio"/></p>	<p>I can name what I learned in the project.</p> <p><input type="radio"/> <input type="radio"/> <input type="radio"/></p>	<p>I know that the opinion of others is as important as mine.</p> <p><input type="radio"/> <input type="radio"/> <input type="radio"/></p>

# Our celebration moment

